



Office Furniture

Modular Workstation, Desking, Seating,
Storage, Social Office and more

Index

Desking

Premium Suites

Page 17 - 33



Executive Suites

Page 34 - 46



Office Desks

Page 47 - 57



Index

Desking

Conference Table

Page 58 – 69



Reception Table

Page 70 – 71



Training Table

Page 72



Cafeteria and Breakout Tables

Page 73 – 77



Seating

Leather and Leatherette Chairs

Page 79 – 87



Mesh Back Chairs

Page 88 – 92



Cushion Back Chairs

Page 93 – 107



Training Room Chairs

Page 108 – 110



Index

Seating

Multipurpose

Page 111 – 117



Cafeteria and Breakout Chairs

Page 118 – 119



Public Seating

Page 120 – 124



Auditorium Seating

Page 125 – 129



Lounge Seating

Page 130 – 133



Active Seating Solution

Page 134 – 137



Cue

Page 138 – 142

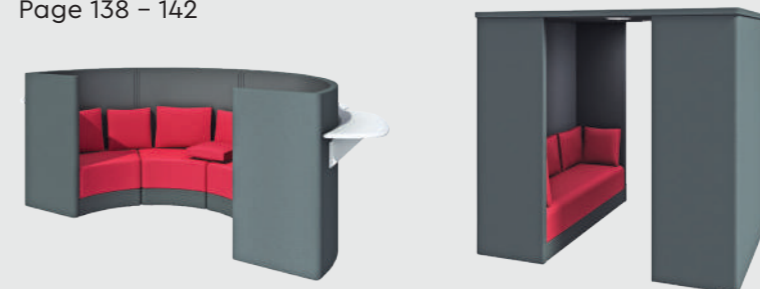

Index

Modular Workstations

Introduction

Page 145 – 147



Mobile Systems

Page 148 – 149



Panel-based Systems

Page 150 – 153



Desk-based Systems

Page 154 – 158



Storage

Aisle and Back Storage

Page 160 – 173

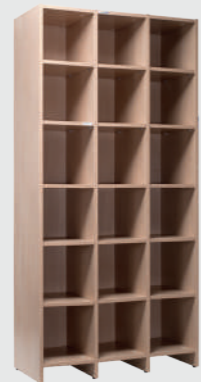

Modular Storage

Page 169



Display Storage

Page 174 – 177



Index

Storage

Modular Display

Page 176



Personal Storage

Page 178 – 182



Conventional Storage

Page 183 – 185

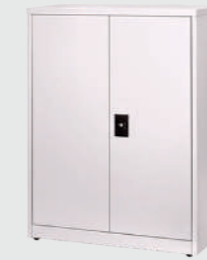

High Density Storage

Page 186 – 193



Social Office

Immerse Work Pod

Page 195



Assert Range

Page 196



Index

Social Office

Topo Range
Page 197



Tetris Range
Page 198



ORBB Range
Page 199



Graph Range
Page 200



Omega Range
Page 201



Personal Workstations
Page 202 – 203



Lamps
Page 204



Neo Bookshelf
Page 205



Index

Lounge

Sofas
Page 207

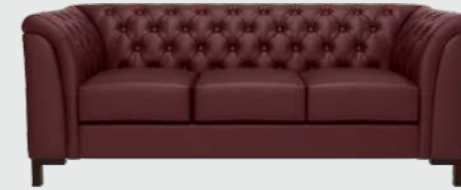

Centre Tables
Page 213



Executive Dining
Page 216



Colour, Finishes and Textures

Colour, Finishes and Textures
Page 219 – 229

Other Segments

Healthcare & Laboratory Furniture
Page 230 – 231





Partnering India In Building A Better Tomorrow.

We are India's largest home & institutional furniture manufacturer since 1936. With a focus on Make in India products, manufactured in state-of-the-art facilities meeting global design, quality and test standards.

Supporting modern nation-building with products, services and initiatives geared towards a greener, healthier, progressive and prosperous future.



125 Years Of Legacy. 1000+ Projects Delivered Annually.

With a rich legacy that spans over 125 years, Godrej is a pioneer across industries in India.

Led by India's largest in-house furniture design team, our aim is to transform spaces with thoughtfully-designed furniture. And our goal is to create brighter homes and offices with products that have the highest design quotient in aesthetics, functionality, and technology.

Godrej Interio at a glance

- India's largest home & institutional furniture manufacturer, since 1936; supporting nation building.
- 95% ex-works TOC performance through project tools and dedicated team to ensure on-time project delivery
- Unique customization capabilities
- Winner of 34 India Design Mark Awards till date.

Widest product portfolio across product lines

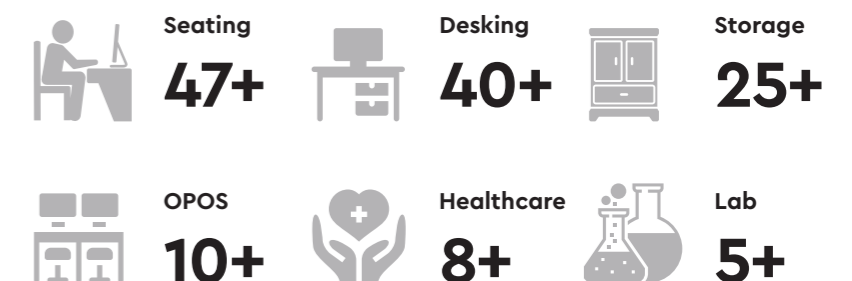

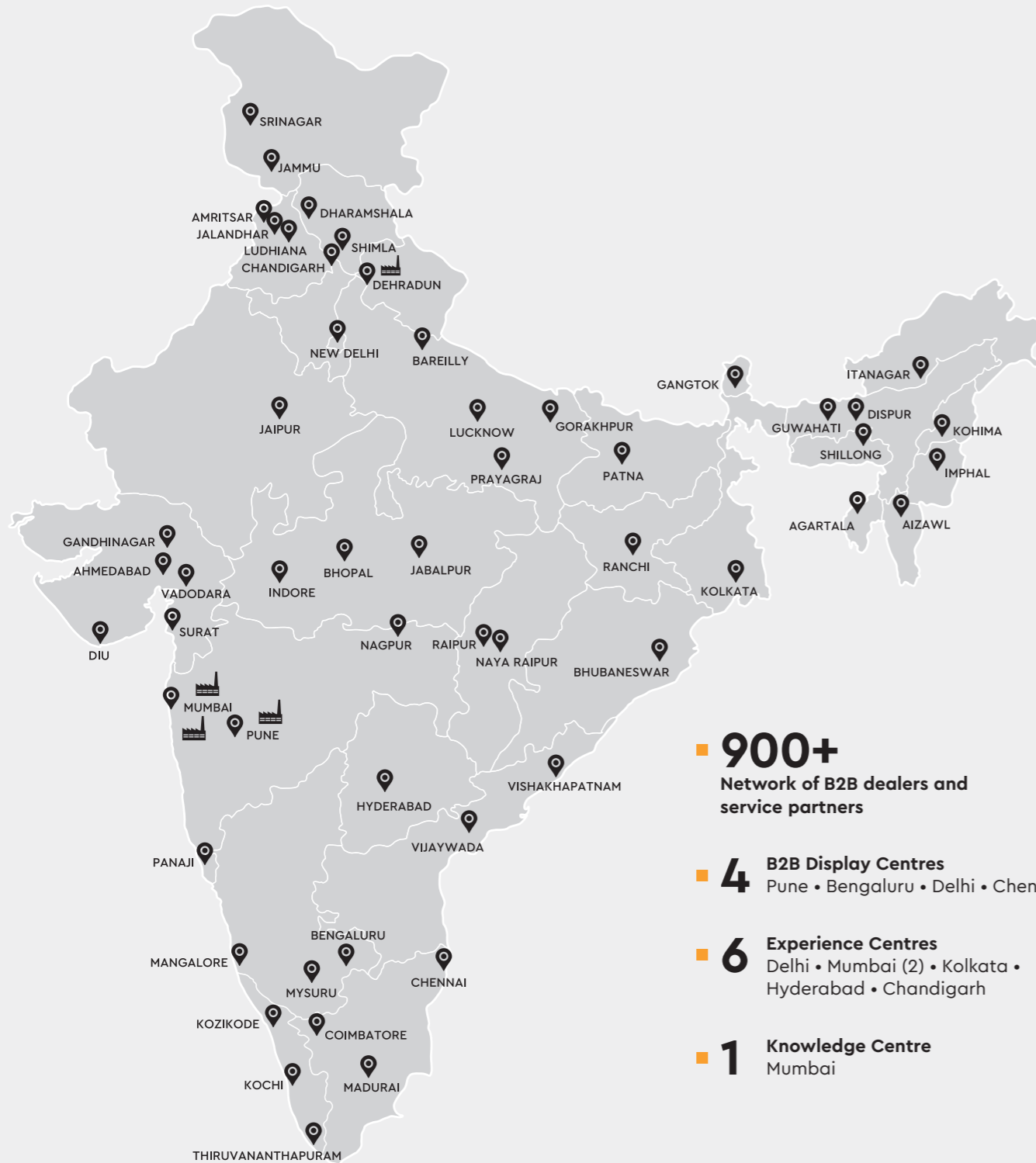

- **900+**
Network of B2B dealers and service partners
- **4** B2B Display Centres
Pune • Bengaluru • Delhi • Chennai
- **6** Experience Centres
Delhi • Mumbai (2) • Kolkata • Hyderabad • Chandigarh
- **1** Knowledge Centre
Mumbai

Our All India Presence

Get complete access to our wide range of workplace solutions across our 900+ dealers and partners in India. Manufactured at our facilities in Vikhroli, Shirwal, Khalapur, Haridwar, and Bhagwanpur, all our workplace products pass through multiple stringent quality checks before they reach you.

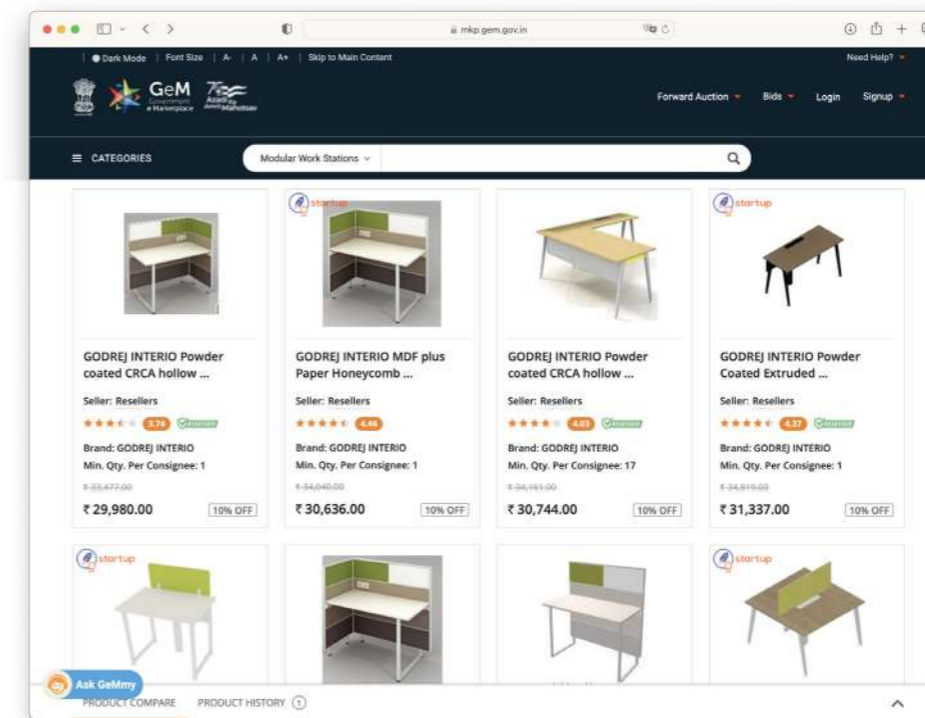

Rating of 4+ on GeM. Compliant & Widely Available.

Godrej Interio is the largest umbrella brand listed on the GeM portal: in 80+ categories under furniture and 190+ categories under office space. Interio has an overall rating of 4+ based on various parameters such as Delivery, Quality, Reliability and Feedback by buyers.

- Among **Top 15** Sellers Registered On GeM
- **60,000+** Product Listings
- **365+** Re-seller Network
- **100+** GeM Categories
- Products Listed In This Dossier Are Available On GeM Portal
- Additional Products Can Be Made Available As Per Requirement

Enforcing Green At Every Step

At Godrej Interio, our sustainability goals are ambitious. We do not just talk, we walk the talk.

We take our work seriously because we know our products and services touch people, transform lives and change the world.

When we add the element of sustainability and green living into what we do, it adds the positivity of hope to the promise of a better future, not only for people but for the planet as a whole.

Godrej interio
talk green.
walk green.



Materials

- Design For Environment
- Green Materials
- LCA



Transportation

- Green Modes Of Transportation



Manufacturing

- Energy Efficiency
- Zero Waste Water Discharge
- Renewal Energy
- Zero Waste Landfill



In Use

- Low Emitting Products
- Green Certification
- AMC



Packaging

- Flat Packaging
- Right Packaging



End Of Life

- Recycling Program
- Safe Disposal

India's First Net Zero Energy Building.

- CII certified state of the art manufacturing facilities across 6 locations
- Designed for the environment: Cradle to grave journey monitored



Greeneco certifications awarded to Vikhroli and Shirwal Units

Largest Portfolio of Certified Products



128+
Green Pro



59+
Green Guard



37+
GRIHA



18+
BIFMA Level 2



18+
SCS Indoor Advantage Gold

Towards Healthier Workspaces

Godrej interio
wellness@work

- Team of certified doctors / ergonomists to assist employee health and productivity challenges at workplace

- Initiatives help reduce healthcare cost

- Ergonomics Program helps organizations improve employee comfort, lowers injuries arising out of sedentary lifestyle at work

- Team is backed by research and advisory experience spanning across corporate, government and healthcare organizations.



Desk-based Systems:

Upbeat+



Design Registered

Features

- Upbeat+ is a complete office furniture setup solution, designed to cater to the various settings in an office space.
- Comes with five different leg designs, and a range of screen finishes and looks which can be mixed-and-matched to create unique office spaces.
- Different options for wire management and design accessories add to the flexibility of the workstation offering.
- It also provides an exhaustive range of sizes and configurations which allow users to create clusters on the basis of their needs.

Details



Storage

Page 160**Aisle and Back Storage****Page 178****Personal Storage****Page 186****High Density Storage****Page 174****Display Storage****Page 183****Conventional Storage**

Reserve

Features

- Individual units which are an ideal fit for aisle-side storage and back units.
- LH and RH units offer a seamless integration of multiple units which brings out the true elegance of this combined configuration.
- Shared units, used between end units help create optimum storage spaces for all your needs.
- Available with legs as well as skirting options so that you can combine them with your workstation easily.



Colour & Material

POWDER COAT

METAL BODY

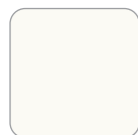

Tex. Bond White

LAMINATE RANGE

WOODEN SHUTTER

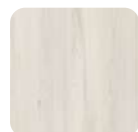

Kitami Elm

Measurements

LFC with Skirting

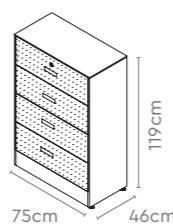

LFC with Legs

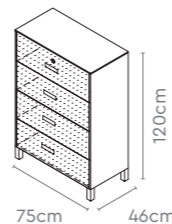

HDU with Skirting

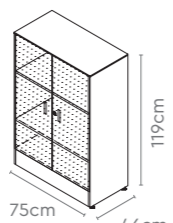

HDU with Legs

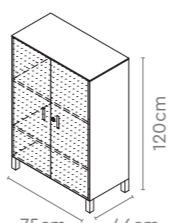

All sizes in cm

	Width	Height
LFC with Skirting	75.0/ 80.0/ 90.0/ 95.0/ 100.0/ 105.0	75.0/ 119.0/ 134.3
LFC with Legs	75.0/ 80.0/ 90.0/ 95.0/ 100.0/ 105.0	75.0/ 120.0/ 135.3
HDU with Skirting	45.0/ 60.0/ 65.0/ 75.0/ 80.0/ 90.0/ 95.0/ 100.0/ 105.0/ 120.0	75.0/ 119.0/ 134.3
HDU with Legs	45.0/ 60.0/ 65.0/ 75.0/ 80.0/ 90.0/ 95.0/ 100.0/ 105.0/ 120.0	75.0/ 120.0/ 135.3

Cushion LFC and Pedestal

Features

- The precision telescopic slider mechanism makes the drawer movement effortlessly smooth.
- An anti-rebound mechanism helps prevent the drawer from coming out after it is pushed in.
- Comes with an anti-tipping mechanism that allows only one drawer to be opened at a time, helping prevent the cabinet from toppling over.
- Comes with two exciting options — wooden and metal top, and in multiple drawer options — 2, 3 and 4.
- 100% VOC-free powder coating.



Colour & Material

POWDER COAT & LAMINATE



Tex. Bond White & Frosty White

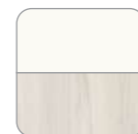

Tex. Bond White & Kitami Elm

Measurements

Metal

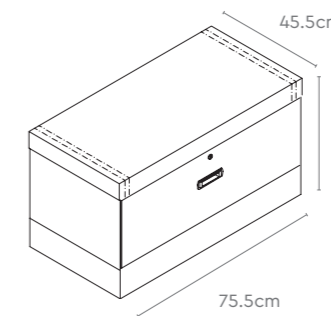

Wooden

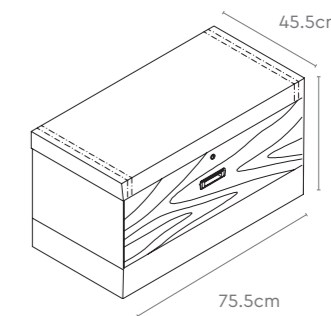

All sizes in cm

	Width	Depth	Height
Metal & Wooden	75.5	45.5	50.2
Front	90.5	45.5	50.2
	105.5	45.5	50.2

Echo

Features

- Available in two ranges — Sliding Door units and Hinge Door units.
- All wood range products come with intelligent optimization of the boards in an effective price range.
- Can be turned into smaller compact packs and carried and assembled effortlessly, thanks to its simple geometrical and construction detailing.
- White laminate is used for the shelves, divider panels, and back panel, giving your interiors a light and spacious look.



Colour & Material

POWDER COAT & LAMINATE



Tex. Bond White & Kitami Elm

Measurements

Echo SDU

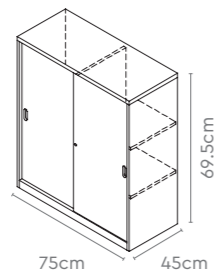

Echo HDU

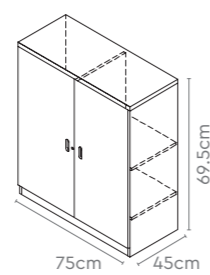

All sizes in cm	Width	Depth	Height
Echo SDU	75.0/ 90.0/ 105.0/ 120.0	45.0	69.5
	75.0/ 90.0/ 105.0/ 120.0	45.0	106.6
	75.0/ 90.0/ 105.0/ 120.0	45.0	121.9
Echo HDU	45.0/ 75.0, 90.0/ 105.0	45.0	69.5
	45.0/ 75.0/ 90.0/ 105.0	45.0	106.6
	45.0/ 75.0/ 90.0/ 105.0	45.0	121.9

Vertical Filing Cabinet

Features

- The precision telescopic slider mechanism makes the drawer movement effortlessly smooth.
- An anti-rebound mechanism helps prevent the drawer from coming out after it is pushed in.
- Comes with an anti-tipping mechanism that allows only one drawer to be opened at a time, helping prevent the cabinet from toppling over.
- Comes in three colour swatches and two drawer options.



Colour & Material

POWDER COAT

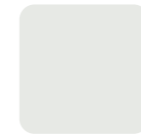

Cloud Grey



Prince Grey

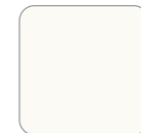

Tex. Bond White

Measurements

2 Drawer VFC

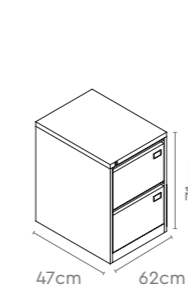

4 Drawer VFC



All sizes in cm	Width	Depth	Height
2 Drawer VFC	47.0	62.0	71.0
4 Drawer VFC	47.0	62.0	132.0

Lateral Filing Cabinet

Features

- The Lateral Filing Cabinet is a minimalistic and sturdy storage option that enables easy access to all your files at one go.
- Ideal for aisles, it comes with anti-tipping and anti-rebound mechanisms to ensure maximum user safety.
- Available in two sizes and drawer configurations to meet all your needs.



Colour & Material

POWDER COAT



Prince Grey

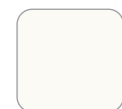

Tex. Bond White



Medieval Town

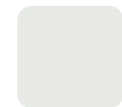

Cloud Grey

POWDER COAT & LAMINATE



Tex. Bond White & Kitami Elm



Prince Grey & Greystone Light

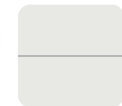

Cloud Grey

Measurements

2 Drawer LFC (with Metal Top)

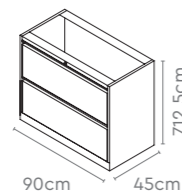

4 Drawer LFC (with Metal Top)

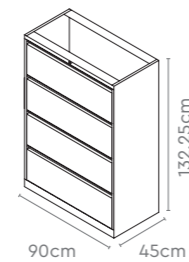

All sizes in cm	Width	Depth	Height
2 Drawer LFC (with Laminate Top)	90.0	45.0	737.5
2 Drawer LFC (with Metal Top)	90.0	45.0	71.25
4 Drawer LFC (with Laminate Top)	90.0	45.0	134.75
4 Drawer LFC (with Metal Top)	90.0	45.0	132.25

Pigeon Hole

Features

- This classic storage solution helps you compartmentalise your mails, couriers, parcels etc in a seamless manner.
- It is a real boon in the communication room, as well as mailrooms of schools, offices, corporates, and government.



Colour & Material

LAMINATE

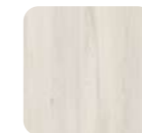

Kitami Elm

Measurements

6' Main Module

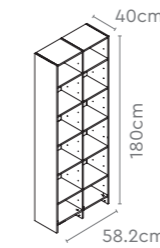

6' Add-on Unit

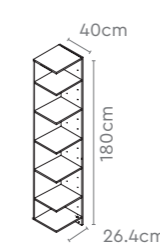

4' Main Module

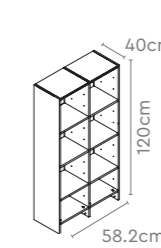

4' Add-on Unit

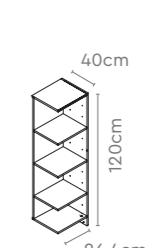

All sizes in cm	Width	Depth	Height
6 Feet Main	58.2	40.0	180.0
6 Feet Add-on	26.4	40.0	180.0
Internal Dimensions of 1 Compartment (6 Feet)	26.4	40.0	27.0
4 Feet Main	58.2	40.0	120.0
4 Feet Add-on	26.4	40.0	120.0
Internal Dimensions of 1 Compartment (4 Feet)	26.4	40.0	27.0

Sliding Door Unit



Features

- The Sliding Door unit's adjustable shelves provide enough storage flexibility to meet all your needs.
- It's sliding door construction makes the most of your aisle space.
- Snap-on die-cast lock keeps it secure, while making it aesthetic.
- Comes with plastic rollers with steel ball bearings for effortlessly smooth door movement.
- Lower height units come in wooden and metal top options.

Measurements

All sizes in cm

	Width	Depth	Height
VSDU-2 with Metal Top	90.0	45.0	71.0
VSDU-2 with Laminate Top	90.0	45.0	73.5
VSDU-5 with Metal Top	90.0	45.0	116.75
VSDU-5 with Laminate Top	90.0	45.0	119.25
VSDU-6 with Metal Top	90.0	45.0	132.0
VSDU-6 with Laminate Top	90.0	45.0	134.5
VSDU-7 with Metal Top	90.0	45.0	183.0
VSDU-9 with Metal Top	120.0	45.0	71.0
VSDU-9 with Laminate Top	120.0	45.0	73.5
VSDU-10 with Metal Top	120.0	45.0	86.25
VSDU-10 with Laminate Top	120.0	45.0	88.75
VSDU-12 with Metal Top	120.0	45.0	116.75
VSDU-12 with Laminate Top	120.0	45.0	119.25

Sliding Door Unit

Colour & Material

POWDER COAT

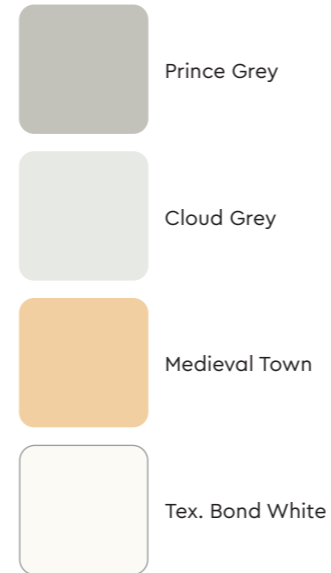

POWDER COAT & LAMINATE

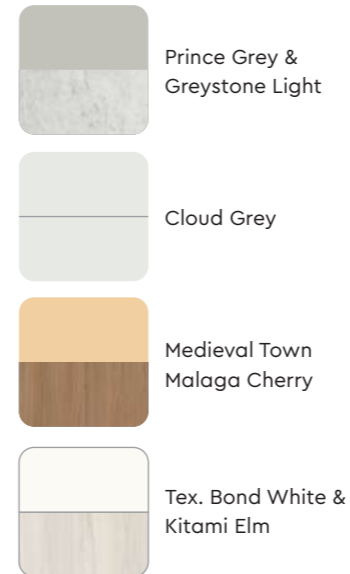

Measurements

VSDU - 2

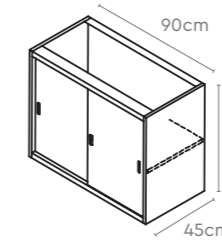

VSDU - 5

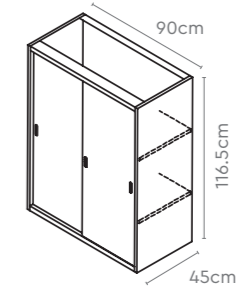

VSDU - 6

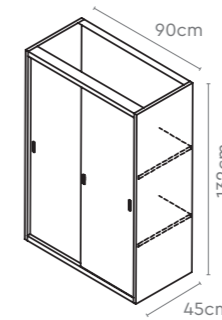

VSDU - 7

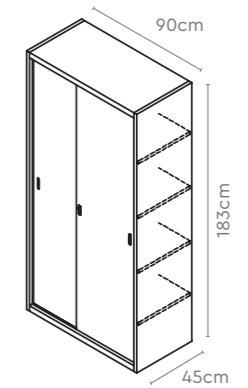

VSDU - 9

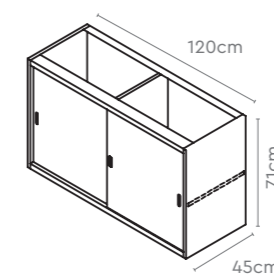

VSDU - 10

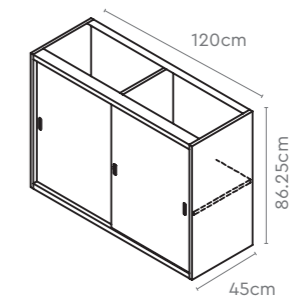

VSDU - 12

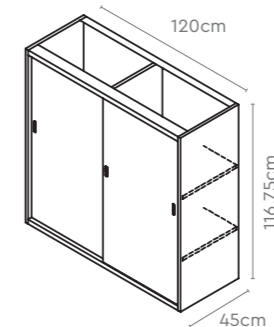

Store Up



Features

- The Store Up is aesthetically-appealing, hassle-free, and ergonomically-designed.
- It makes the most of the corner spaces in your office, enabling optimum utilisation of your storage space.
- Can be installed in an unending line up with no limit to the number of main plus add-on bodies.
- Made of a sturdy metal carcass structure.

Measurements

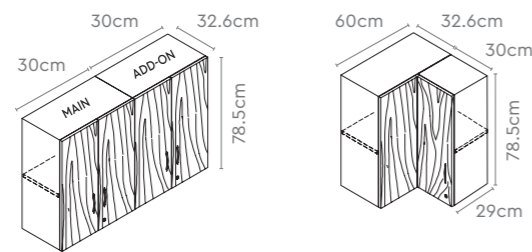

Colour & Material

POWDER COAT & LAMINATE

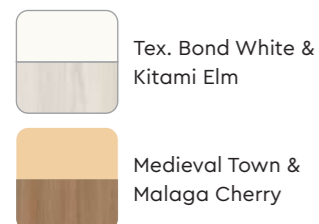

All sizes in cm	Width	Depth	Height
Store Up	30.0	32.6	78.5
	45.0	32.6	78.5
	60.0	32.6	78.5
	80.0	32.6	78.5
	90.0	32.6	78.5

Gain Pro Storage Unit

Features

- Gain Pro Storage optimises floor space, improves workflow, and enriches productivity.
- No matter the size of the room, every available space, from floor to ceiling and wall to wall, is aptly utilised to meet your storage requirements.
- Can be paired with any of our secure locking systems, be it Cam, Digital or Numeric locks, now with a 3-point locking mechanism.
- Also available in metal & glass combination door units for displaying awards, books, collectables and mementoes.



Colour & Material

POWDER COAT



LAMINATE

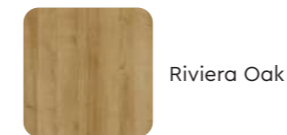

Measurements

Hinge Door (Metal)



Hinge Door (Wood)



Proportion

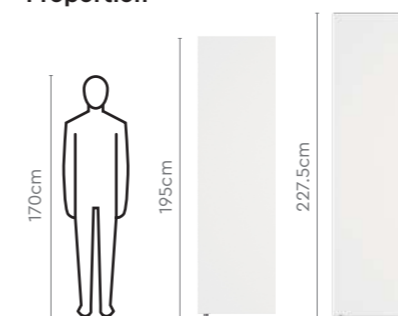

All sizes in cm	Width	Depth	Height
Hinge Door	45.0/ 60.0/ 90.0/ 120.0	45.0	195.0/ 227.5



Design Registered

Mobile Caddy



Features

- The Mobile Caddy's complete knock-down construction enables customised arrangements for different work situations.
- It's ideal for both teams and individual requirements.
- Comes with lockable casters for outer body, and an anti-tilt caster for the pedestal, thereby ensuring flexibility and overall stability.
- Available in TDU+RH Drawer or TDU+LH Drawer configurations.

Measurements

Mobile Caddy LH

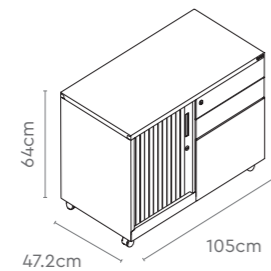

Mobile Caddy RH

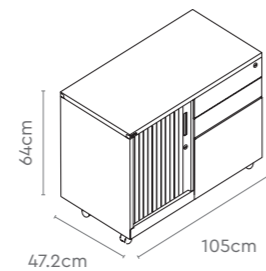

Colour & Material

POWDER COAT



All sizes in cm			
Caddy	Width	Depth	Height
	105.0	47.2	64.0

Cell Phone Lockers

Features

- The Cell Phone Locker comes in two variants: 30-door Wall Mounting and 60-door Wall Mounting/Standalone (with aluminium base).
- Comes with a 180 degree opening door for more convenience, and is available in a fully assembled construction.
- Ideal for workspaces with limited wall space.
- Can be used to store cell phone, wallets and other day-to-day valuables, be it at a school, office, or at home.



Colour & Material

POWDER COAT



Measurements

30 Door Locker Wall Mounted

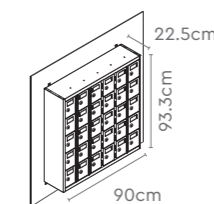

60 Door Locker Wall Mounted

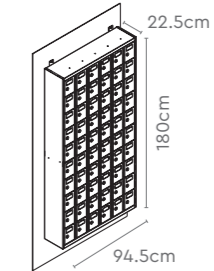

60 Door Locker Stand Fixed

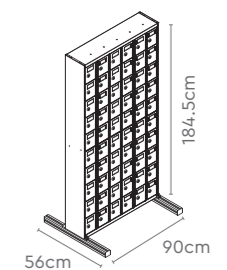

All sizes in cm	Width	Depth	Height
30 Door Locker Wall Mounted	90.0	22.5	93.3
60 Door Locker Wall Mounted	90.0	22.5	180.0
60 Door Locker Stand Fixed	94.5	56.0	184.5

Tambour Door Unit



Features

- Tambour's doors roll inwards, preventing blockage of space while in use.
- Adds to the aesthetics of your space, thanks to its translucent double shutters.
- Comes with central locking for optimal security.
- Can be paired with a wide range of accessories as per your needs.

Measurements

TDU - Variant 1

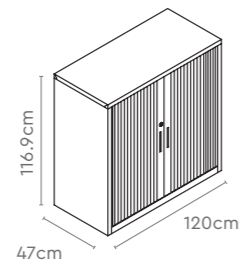

TDU - Variant 2

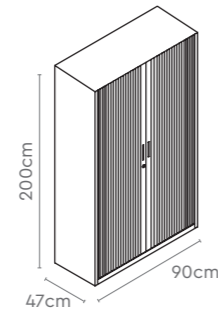

Colour & Material

POWDER COAT



Tex. Bond White

All sizes in cm	Width	Depth	Height
TDU	75.0	47.0	69.0/ 116.9
	90.0	47.0	69.0/ 116.9/200.0
	120.0	47.0	69.0/ 116.9 /200.0

Horizontal Plain Filing Cabinet



Features

- An ideal architectural storage solution that helps store drawing/plan files laterally.
- It has 6 drawers with ample storage and label holders for each one.
- It is mounted on a stand with a clearance of 125mm that facilitates easy floor cleaning.
- Its complete knock-down construction with Pop rivets makes it a good solution for quick installation and easy transportation.

Measurements

HPFC

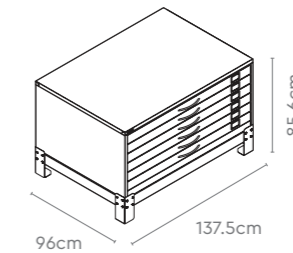

Colour & Material

POWDER COAT

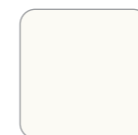

Tex. Bond White



Prince Grey

All sizes in cm	Width	Depth	Height
HPFC	137.5	96.0	85.6

Bookcase

Features

- These bookcases are every bookworm's dream come true.
- They are unmatched in their utility to store books and records.
- Come with a glass door to identifying the contents inside easily.
- Available in 2-door and 4-door options.



Colour & Material

POWDER COAT & LAMINATE

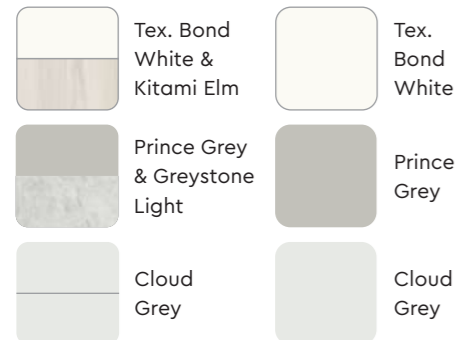

Measurements

2 Door Book Case (Laminate Top)

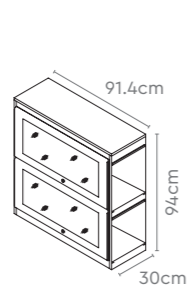

4 Door Book Case

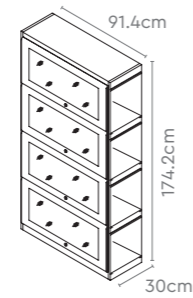

Proportion

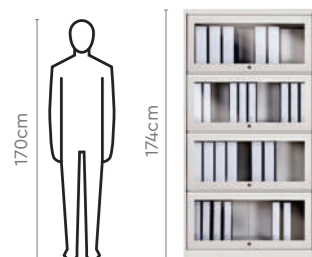

All sizes in cm	Width	Depth	Height
2 Door Bookcase (Straight Edge Top) Laminate Top	91.4	30.0	94.0
2 Door Bookcase (Post Formed Top)	91.4	30.0	94.7
4 Door Bookcase	91.4	30.0	174.2

Glass Door Storwel

Features

- The Glass Door Storwel provides safe and convenient storage of books, administrative files, stationery etc.
- Comes with 4 adjustable shelves that can store just about anything, and with a 3-way bolting device, and 6 lever lock for maximum security.
- The glass door makes it aesthetically-appealing, while also helping you identify the contents inside faster.



Colour & Material

POWDER COAT



Measurements

Glass Door Storwel

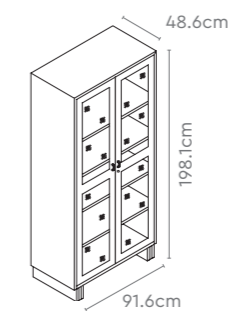

All sizes in cm	Width	Depth	Height
Glass Door Storwel	91.6	48.6	198.1

Gain Pro Display Unit

Features

- Gain Pro's combo is unmatched in its ability to store books and records, while providing an aesthetic backdrop to your office space.
- No matter the size of the room, every available space, from floor to ceiling and wall to wall, is aptly utilised to meet your storage requirements.
- Different modules and configurations can be stacked together to form a cluster that satisfies all your office storage needs.



Design Registered

Colour & Material

POWDER COAT



Measurements

Glass Door



Combi Door



Proportion

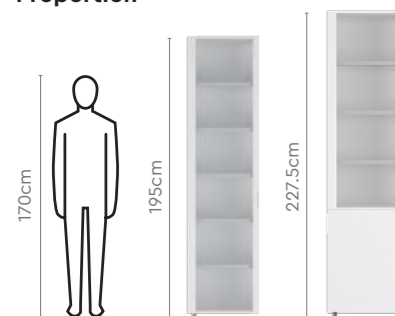

All sizes in cm	Width	Depth	Height
Glass Door	45.0/ 60.0/ 90.0/ 120.0	45.0	195.0/ 227.5
Combi Door	45.0/ 60.0/ 90.0/ 120.0	45.0	227.5

Sliding Glass Door Unit

Features

- The Sliding Glass Door Unit saves aisle space, and forms an aesthetic backdrop to your office space.
- Adjustable shelves provide flexibility in storage layouts and type.
- Comes with aesthetically appealing snap-on die-cast lock for security.
- Plastic rollers with steel ball bearings aid smoother door movement.



Colour & Material

POWDER COAT



POWDER COAT & LAMINATE

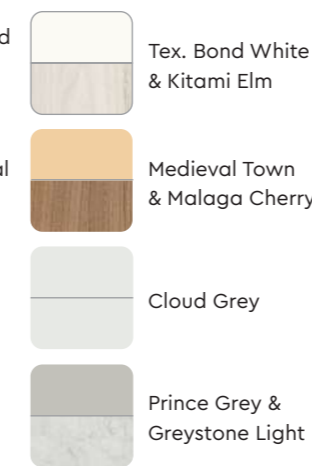

Measurements

Sliding Glass Door Storwel

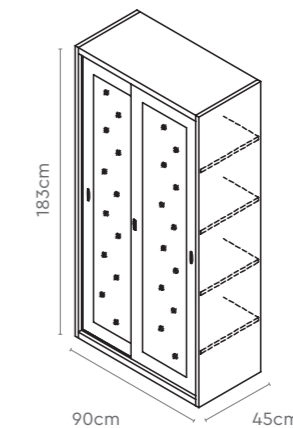

All sizes in cm	Width	Depth	Height
VSDU with Metal Top	90.0	45.0	183.0

Nova

Features

- An efficient personal storage solution that makes your work desk clutter-free.
- Available in free-standing & top-supporting options.
- Comes complete with an anti-rebound mechanism to preempt hurt, injury or damage.



Colour & Material

POWDER COAT



Black Ink



Cloud Grey

Measurements

Free Standing
BBF Pedestal

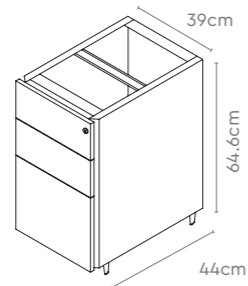

Top Supporting
BBF Pedestal

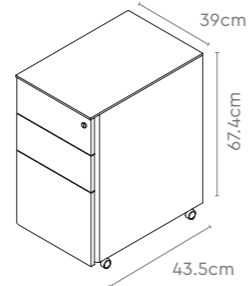

All sizes in cm	Width	Depth	Height
Free standing BBF Pedestal	39.0	44.0	64.6
	39.0	59.0	64.6
Top Supporting BBF Pedestal	39.0	43.5	67.4

Wooden PLU

Features

- These Wooden lockers have been specially designed for offices with open floor plans.
- Its aesthetic design is versatile enough to sit anywhere in your workplace.
- Comes in diverse locking systems, from traditional key based locking systems to more advanced keyless solutions, all the while providing easy access as well as high security.
- Equipped with a name plate to help you identify your personal locker easily.



Colour & Material

LAMINATE

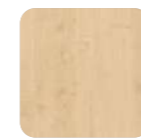

Thansau Maple

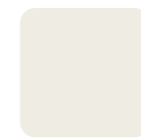

Frosty White

Measurements

8 Door
Main Module

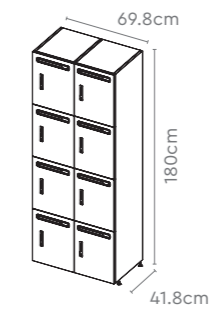

4 Door
Main Module

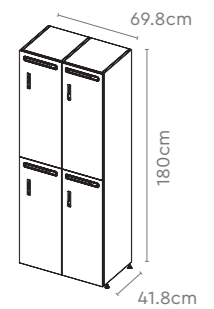

4 Door
Add On Module



2 Door
Add On Module

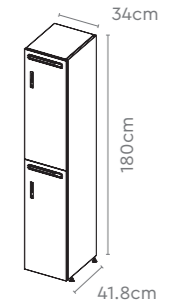

All sizes in cm	Width	Depth	Height
Main Unit	69.8	41.8	180.0
Add On Unit	34.0	41.8	180.0

Gain Pro Locker Unit



Design Registered

Features

- Gain Pro lockers make optimum use of the floor space, and can substitute dedicated individual pedestals at each workstation, creating substantial cost savings in furniture and real estate.
- Each locker shelf comes with a load-bearing capacity of up to 20 kgs, and is more than apt for everyday office storage needs.
- Keep employee mail and packages organised and secure with Gain Pro lockers, also available with envelope slots.

Measurements

2 Doors without envelope slot



4 Doors without envelope slot



6 Doors without envelope slot



2 Doors with envelope slot



4 Doors with envelope slot



6 Doors with envelope slot



Proportion

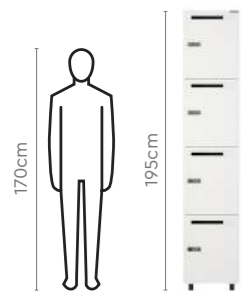

Gain Pro Locker Unit

Colour & Material

METAL

COMPLETE UNIT

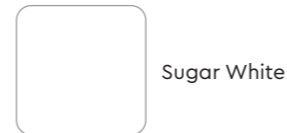

UNIT CLUSTER

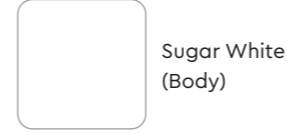
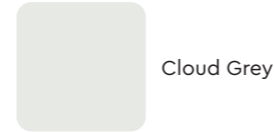

Measurements

2 Door Unit Cluster



4 Door Unit Cluster



6 Door Unit Cluster



All sizes in cm

	Width	Depth	Height
Locker	45.0	45.0	195.0
2 Door Unit Cluster	270.0	45.0	195.0
4 Door Unit Cluster	270.0	45.0	195.0
6 Door Unit Cluster	270.0	45.0	195.0

Personal Locker Unit

Features

- The Personal Locker units come with label holders for easy identification.
- They can be customised as per your needs, as a single or a multi-unit configuration, and are available with and without a locking mechanism.
- Hanging rods are available in the 1 and 2-Door locker models.
- Stands are also available for the 1 Locker, 2 Locker or 3 Locker combinations, allowing for easy cleaning.
- Comes with 4 types of locking mechanisms — Hasp, Cam, Numeric and Digital.



Colour & Material

POWDER COAT



Tex. Bond White

Measurements

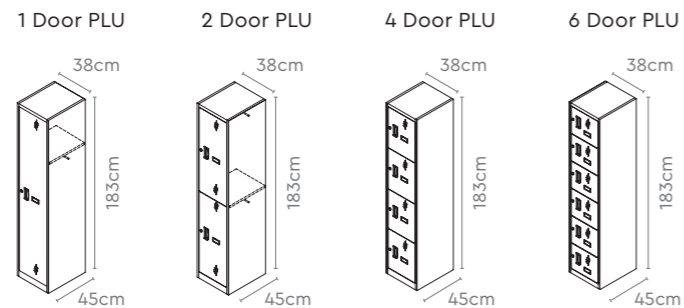

All sizes in cm	Width	Depth	Height
1, 2, 4, 6 Door PLU (Main - Add On)	38.0	45.0	183.0
Stand for 1 Locker	38.0	45.0	12.5
Stand for 2 Locker	76.0	45.0	12.5
Stand for 3 Locker	114.0	45.0	12.5

Storwel Plain

Features

- The Storwel Plain provides safe and convenient storage of books, administrative files, stationery etc.
- Comes with 4 adjustable shelves that can store just about anything, and with a 3-way bolting device, and a 6-lever lock for maximum security.
- It's all-metal body gives it a classic look and feel.



Colour & Material

POWDER COAT



Prince Grey

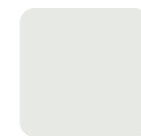

Cloud Grey



Tex Bond White



Medieval Town

Measurements

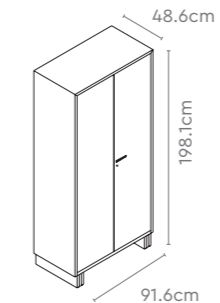

All sizes in cm	Width	Depth	Height
Storwel Plain	91.6	48.6	198.1

KD Range

KD Plain



KD Minor



Colour & Material

POWDER COAT



Features

- The KD Plain provides safe and convenient storage of books, administrative files, stationery etc.
- Comes with 4 adjustable shelves that can store just about anything, and with a 3-way bolting device for maximum security.
- Its knock-down construction makes it easy to assemble and disassemble.

Measurements

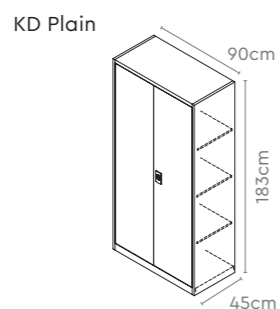

- The KD Minor provides safe and convenient storage of books, administrative files, stationery etc.
- Comes with 2 adjustable shelves that can store just about anything, and with a 3-way bolting device, and a 6-lever lock for maximum security.
- It's all-metal body gives it a classic look and feel.

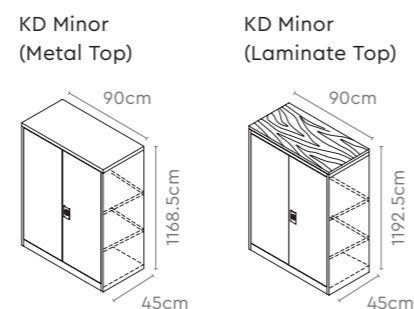

All sizes in cm	Width	Depth	Height
KD Plain	90.0	45.0	183.0
KD Minor (Metal Top)	90.0	45.0	1168.5
KD Minor (Laminate Top)	90.0	45.0	1192.5

Minor Plain

Features

- The Minor Plain provides safe and convenient storage of books, administrative files, stationery etc.
- Comes with 2 adjustable shelves that can store just about anything, and with a 3-way bolting device, and a 6-lever lock for maximum security.
- It's all-metal body gives it a classic look and feel.



Colour & Material

POWDER COAT



Measurements

Minor Plain

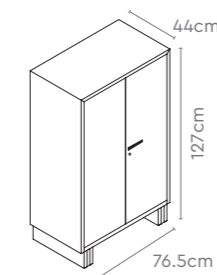

All sizes in cm	Width	Depth	Height
Minor Plain	76.5	44.0	127.0

Optimizer Plus

The Optimizer Plus is an intelligent mobile storage system which saves on aisle spaces unlike other storages. It comes in Push-Pull, Drive, and Power Drive options, complete with the highest standards of safety, security, and ease of use.

Power Drive



Drive



Push-Pull



Optimizer Plus

Colour & Material

POWDER COAT



Common Features



Name Tag



Adjustable Shelves



Cross Member Back Panel (Left) & Solid Back Panel (Right)

Colour & Material

POWDER COAT



Accessories



Instadex File with Cradle Pair



Rollout Shelf



Hinged Doors with Locking



Stool

Optimizer Plus

With Power Drive



Features

- Equipped with a Smart Touch Control Panel that's positioned at a suitable height for ease of access, and comes with different functions such as START, STOP, RESET & UNLOCK.
- Is complete with a centralised locking system that ensures maximum security to all your documents.
- A central power switch offers convenience in operation.
- Easy to install as it can be fixed directly on the ground or be embedded in the pavement, which eliminates grouting and prevents civil floor work.
- Its innovative design is in compliance with the international safety standards for a better user experience.

Measurements



All sizes in cm	Width	Depth	Height
Optimizer Plus: Power Drive	120.0	40.0	198.0/ 236.1

Optimizer Plus with Power Drive

Colour & Material

POWDER COAT



Measurements

M2 Motorized with Platform

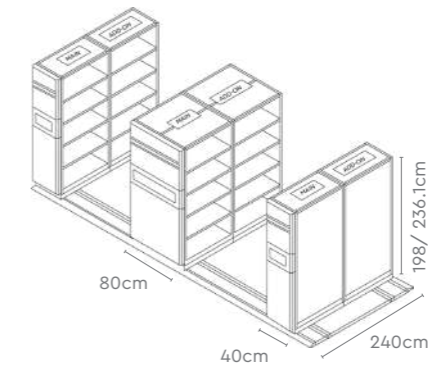

M3 Motorized with Platform

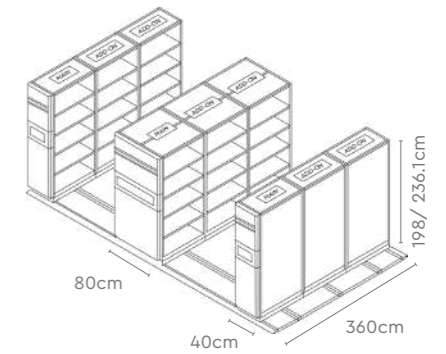

M4 Motorized with Platform

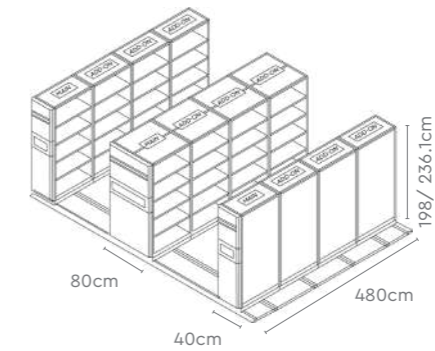

Details

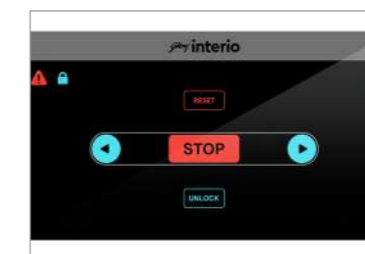

Smart Touch Control Panel



Centralized Locking



Central Power Switch



Wooden Platform

Optimizer Plus

With Drive



Features

- Drive comes with an ergonomically designed and positioned wheel that provides a firm grip for operation, while sprucing up the aesthetics of your storage area.
- Has individual locking knobs for each unit for additional safety.
- The front and rear panels are designed with perforations for ventilation.
- Is complete with a centralised locking system that ensures maximum security to all your documents.
- Easy to install as it can be fixed directly on the ground or be embedded in the pavement, which eliminates grouting and prevents civil floor work.

Measurements



All sizes in cm	Width	Depth	Height
Optimizer Plus: Drive	120.0	40.0	198.0/ 236.1

Optimizer Plus with Drive

Colour & Material

POWDER COAT



Measurements

D2 Drive Type

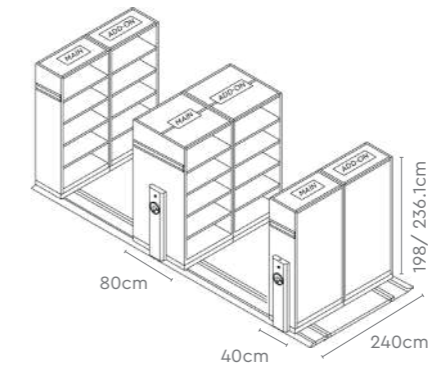

D3 Drive Type

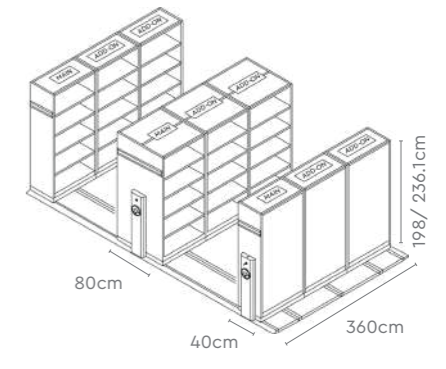

D4 Drive Type

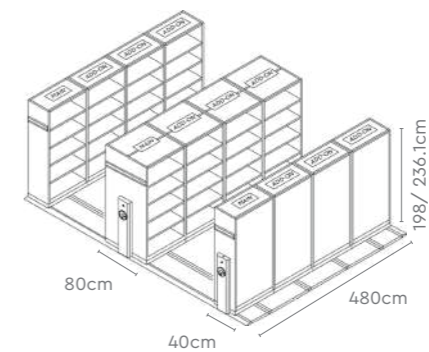

Details



Centralized Locking



Locking Knob on Each Unit



Ventilation Ready



Wooden Platform

Optimizer Plus

With Push-Pull



Features

- Push-Pull has a contemporary design that complements any indoor ambience.
- Comes equipped with C-shaped handles that minimise the effort and facilitate smooth movement of the units.
- The front and rear panels are designed with perforations for ventilation.
- Is complete with a centralised locking system that ensures maximum security to all your documents.
- A locking stiffener is provided on the last unit to lock all units together.

Measurements



All sizes in cm	Width	Depth	Height
Optimizer Plus: Push-Pull	120.0	40.0	198.0

Optimizer Plus with Push-Pull

Colour & Material

POWDER COAT



Measurements

P1 Push-Pull Type

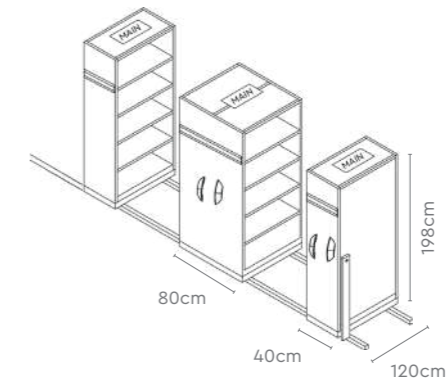

P2 Push-Pull Type

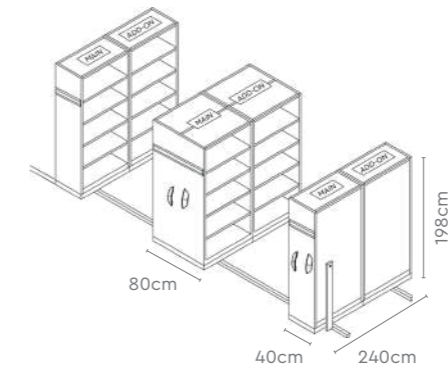

Details



Ventilation Ready

Centralized Locking

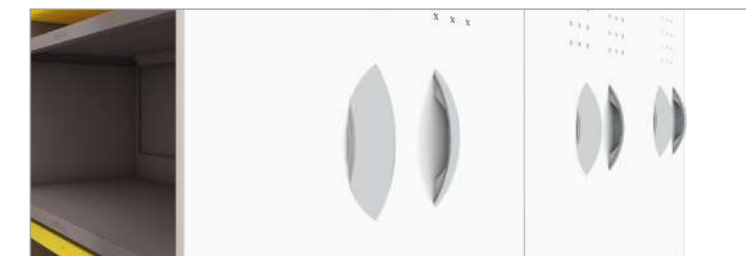

Push-Pull Handle

SPECTRUM

THE COLOUR EXPERIENCE

Colours, Materials, Finishes and Textures

Godrej Interio's Colour System — Spectrum — presents infinite possibilities for creating fresh and inspiring themes for workplaces. In the following pages, we demonstrate some of these possibilities using a curation of workplace themes, and a glimpse of the 100+ colours, materials, finishes and textures we offer.

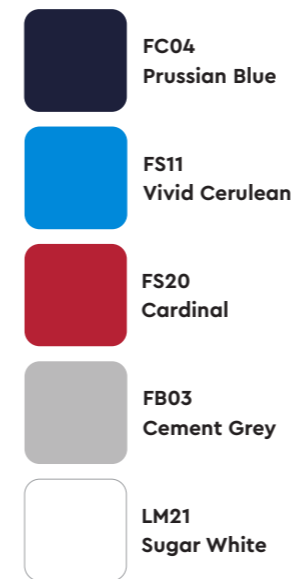

Inspired by Culture

A city rich in history, Jodhpur's architecture, colours and people signify a beautiful blend of traditions and warmth. Even as the city is adapting to urbanization, it communicates to stay rooted while exploring the new.

Inspired by Flavour

Spices define the nature of food, their intensity and combinations can enhance the punch in the flavour. A combination of such colours and materials triggers the required spark for an interesting conversation.





- FO69 Luminous
- PW34 Texas Yellow
- FB03 Cement Grey
- FO24 Blue Iceberg
- LM21 Sugar White

Inspired by Spry

Playing sports is not only a wonderful way to stay fit but it is also one of the best stress busters. Aspects of a game such as energy, team spirit and problem solving are synonymous to today's workforce.



- PW16 Sunset Sky
- PW11 Vivid Cerulean
- PW27 Sugar White
- MB114 Verade Oak Soft Natural

Inspired by Summer

A little bit of summer vacation is what might be the best time of the year; a sense of serene space may be with friends, sun, sand and sea is a longing state of mind.

Inspired by Refresh

Urban spaces have made us detached from nature. A refreshing, exhilarating experience of space with greens is a welcome break.

- FO14 Vitamin Bright
- FO33 Tree Mist
- PW27 Tex Bond White
- LM44 Warm Grey
- MB116 Amati PC







Inspired by Zest

Food is a dominant part of one's culture that helps strengthen the community at a workspace, and chilies are the most common ingredients that can bind multi-cultural cuisines together.



- FL06 Garnet
- PW27 Tex Bond White
- PW14 Gargoyle
- FK01 Black Ink
- LM104 Kitami Elm



-  FL04
Prussian Blue
-  LT52
Dark Tan
-  FL01
Black Ink
-  MB112
Tobacco Ash

Inspired by Regal

A meet that could shape the future needs the right setting and tone. An earthy and contemporary palette brings a feeling of power and authority.









Inspired by Active

Health is the highest priority for a new age worker. Healthy living is a growing focus area that urges us to practice an active lifestyle even at work. It makes us feel positive, energetic and motivated.

-  FS05
Leaf Green
-  FC02
Dark Tangerine
-  FS20
Cardinal
-  PW11
Vivid Cerulean
-  LM21
Sugar White



Foam Laminated Fabric Seating (FL)

-  FL01
Black Ink
-  FL04
Prussian Blue
-  FL06
Garnet
-  FL07
Royal Blue
-  FL08
Saddle Brown
-  FL10
Earth Stone
-  FL14
Vitamin Bright
-  FL56
Amethyst Regale

Breakout Fabric Seating (FB)

-  FB03
Cement Grey
-  FB04
Ink
-  FB18
Milan Red
-  FB51
Shadow

Sofa Fabric Seating (FS)

-  FS02
Dark Tangerine
-  FS04
Denim
-  FS05
Leaf Green
-  FS11
Vivid Cerulean
-  FS20
Cardinal
-  FS72
Mink
-  Peacock
-  Flame
-  Citron
-  Cement Grey

Crepe Fabric Seating (FC)

Voila



Knitted Fabric Seating (FK)

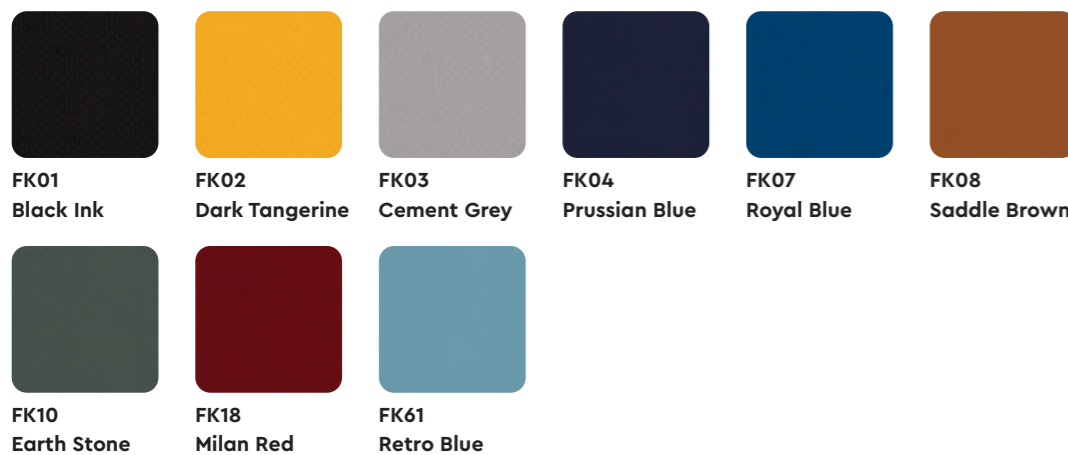

Leatherette Sofa (LS)



Leather (LT)



Leatherette Chair (LC)



Net / Micro Mesh / Spacer Fabric Seating (NM & SF)

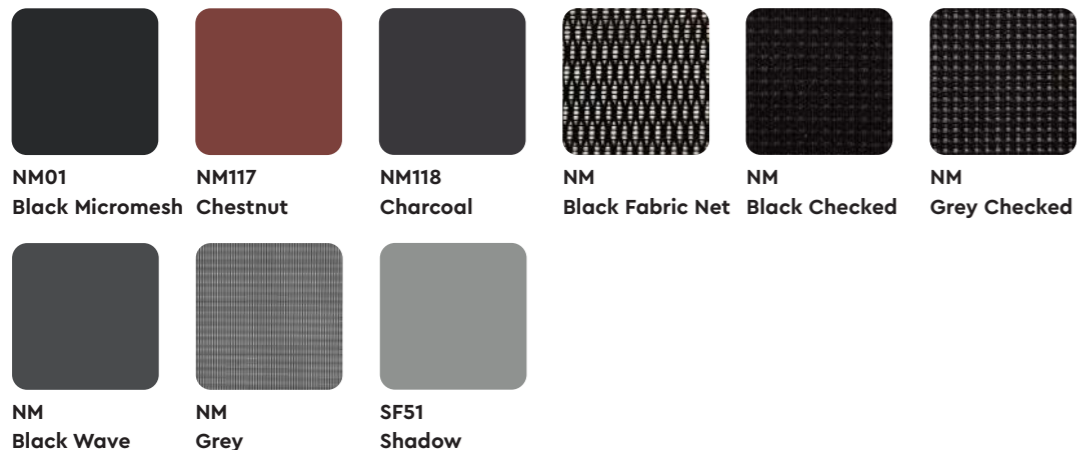

Plush Fabric (FP)



Unwind Range

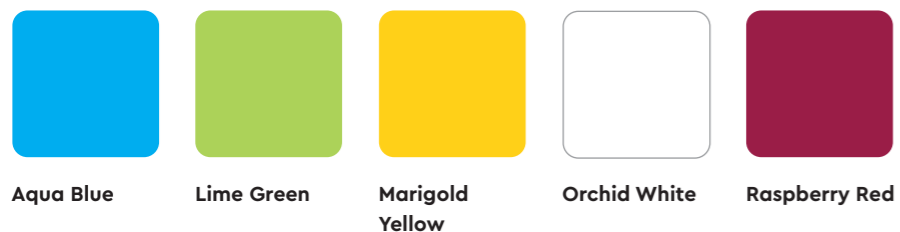

Laminate (LM)

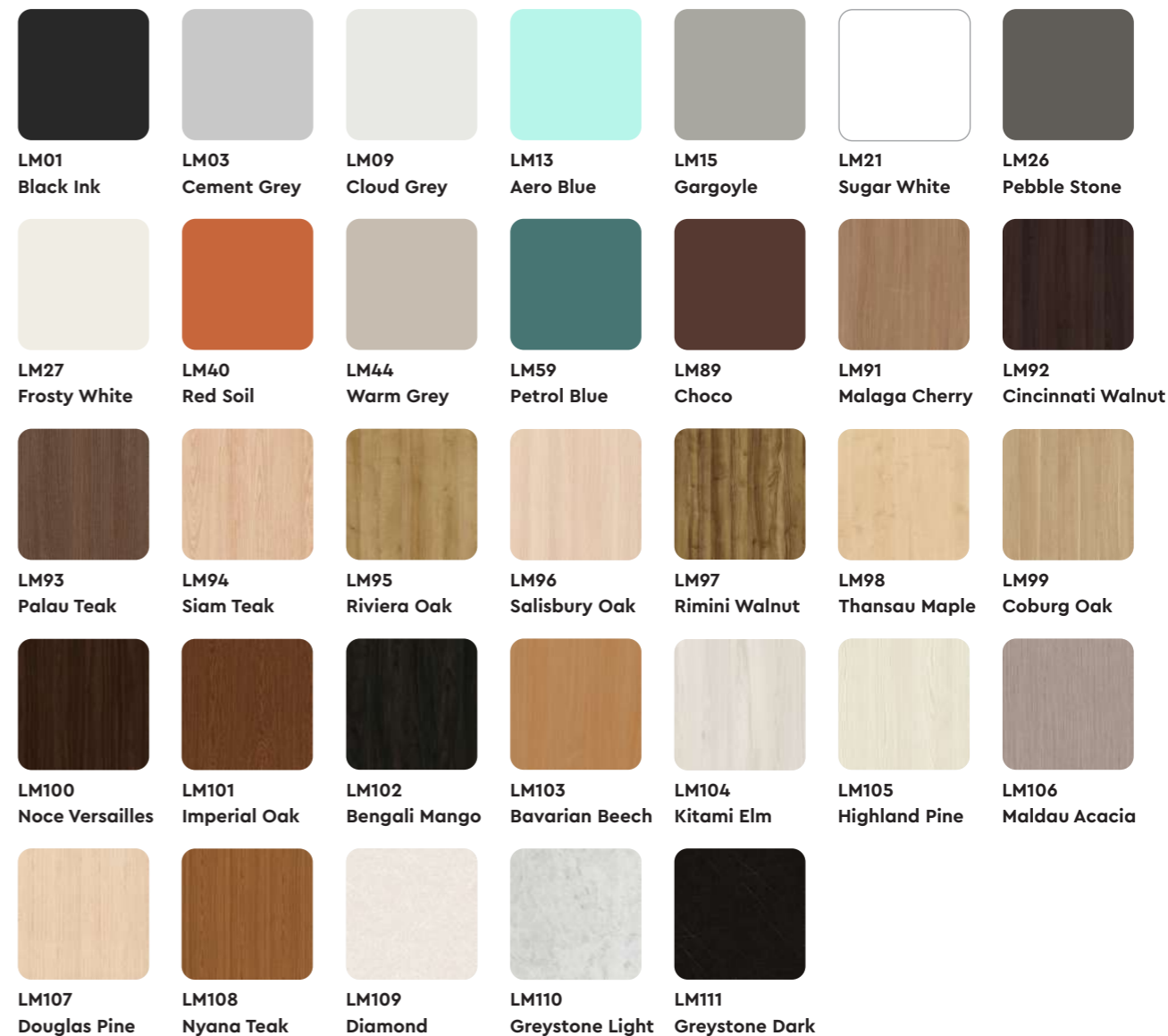

Membrane Range (MB)

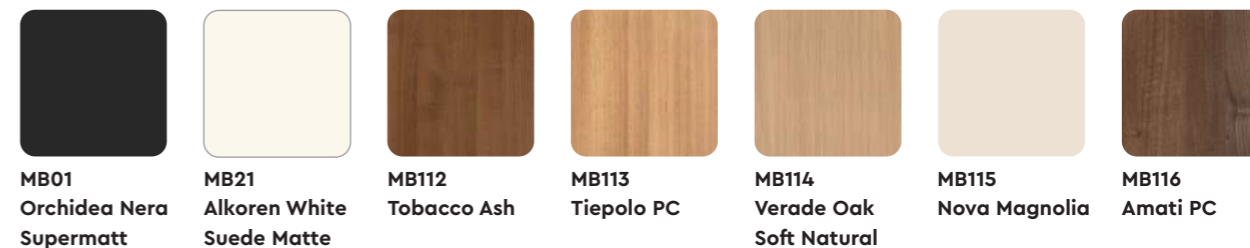

Fabric Modular (FO)

						
FO02 Dark Tangerine	FO03 Cement Grey	FO04 Prussian Blue	FO05 Leaf Green	FO06 Garnet	FO07 Royal Blue	FO08 Saddle Brown
						
FO10 Earth Stone	FO11 Vivid Cerulean	FO12 Azure	FO13 Aero Bue	FO14 Vitamin Bright	FO15 Gargoyle	FO16 Sunset Sky
						
FO19 Indian Red Chili	FO20 Cardinal	FO22 Orchid Purple	FO24 Blue Iceberg	FO25 Country Green	FO28 Boysenberry	FO29 Amethyst
						
FO30 Powder Blue	FO31 Blue Grass	FO33 Tree Mist	FO35 Victorian Gold	FO36 Cream	FO38 Oranger Spark	FO39 Burnt Orange
						
FO41 Young Wine	FO42 Copper Moon	FO44 Warm Grey	FO45 Stone Path	FO46 Roasted Bean	FO47 Champagne	FO54 Fresh Leaf
						
FO55 Plum Pastel	FO57 Baby Blue	FO58 Caspian Sea	FO60 Blue Ivy	FO62 Citrus	FO63 Green Sea	FO65 Conifer
						
FO67 Jungle Cane	FO69 Luminous	FO70 Fuscia	FO70 Jaipur Pink	FO73 White Sand	FO75 Acron	FO76 Indian Coffee
						
FO85 Granada	FO86 Latte	FO87 Sliver Line	FO88 Caramel			

Powder Coat (PW)

						
PW01 Black Ink	PW02 Dark Tangerine	PW03 Cement Grey	PW04 Prussian Blue	PW05 Leaf Green	PW06 Garnet	PW09 Cloud Grey
						
PW11 Vivid Cerulean	PW13 Aero Blue	PW14 Gargoyle	PW16 Sunset Sky	PW18 Indian Red Chilli	PW20 Cardinal	PW21 Sugar White
						
PW24 Blue Iceberg	PW26 Pebble Stone	PW27 Tex Bond White	PW33 Tree Mist	PW34 Texas Yellow	PW40 Red Soil	PW41 Young Wine
						
PW44 Warm Grey	PW48 Slate Grey	PW54 Fresh Leaf	PW66 Lime	PW68 Banana Yellow	PW74 Horizon	PW78 Medieval Town
						
PW81 Sepia Brown	PW82 Prince Grey	PW83 Platinum Silver	Matt Taupe White			

Godrej interio

HEALTHCARE

Visit our Healthcare Experience Centre to experience the latest healthcare products from our range, firsthand — from patient care, to medical screening to office & leisure furniture.

Products Available: ICU Beds, Examination Beds, Gynaec Examination Couch, Recovery Bed, Emergency Trolley, Nursing Station, Office Furniture and more.



Lab



Fusion



Nucleus



Aeolus

Godrej interio

Available in over 600 locations in India.

North: Delhi, Chandigarh, NCR, Lucknow
South: Chennai, Bengaluru, Hyderabad, Kochi
West: Mumbai, Ahmedabad, Bhopal, Pune
East: Kolkata, Bhubaneswar, Guwahati, Patna

Godrej & Boyce Mfg. Co. Ltd.

Godrej Interio,
Pirojshanagar, Vikhroli (W),
Mumbai 400 079

Toll Free Number: 1800-209-5511

Email: interiooffice@godrej.com

Fax: +91-22-6796 1503

Put some play into your work by visiting
godrejinterio.com/business

Follow us on /godrejinterio



Godrej interio

talk green.
walk green.

An initiative by Godrej Interio,
the first Indian furniture
company with GREENGUARD
certified products.



India's
Most Desired Brand
TRA Research
Furniture Category
July 2021



India's
Most Trusted Brand
TRA Research
Furniture Category
February 2022



**Franchise India
Retail Brand
of the Year**
Speciality/Furniture
Retail Category
December 2022



Marksmen Daily
Most Preferred Brand
2022

MODULAR FURNITURE . DESKING . SEATING . STORAGE . INTERIORS . LAB . HEALTHCARE . HOME



The GREENGUARD Certification Program gives assurance that products designed for use in indoor spaces meet strict chemical emission limits, which create healthier interiors. The certification qualifies for LEED credits and IGBC credits.

In keeping with the Godrej policy of continuous development and improvement, the design, dimension and specification may be updated without prior notice or obligations. Form, Colour and Finish of product in this document are representative of design intent and may vary from actual. Colour options depicted in this catalogue are as close to what modern printing processes allow. All dimensions are in 'cm' and are subject to commercial tolerance. Our products are meant for indoor use only.

B2BGOVTDOSI2023