



Office Furniture

Modular Workstation, Desking, Seating,
Storage, Social Office and more

Index

Desking

Premium Suites

Page 17 - 33



Executive Suites

Page 34 - 46



Office Desks

Page 47 - 57



Index

Desking

Conference Table

Page 58 – 69



Reception Table

Page 70 – 71



Training Table

Page 72



Cafeteria and Breakout Tables

Page 73 – 77



Seating

Leather and Leatherette Chairs

Page 79 – 87



Mesh Back Chairs

Page 88 – 92



Cushion Back Chairs

Page 93 – 107



Training Room Chairs

Page 108 – 110



Index

Seating

Multipurpose

Page 111 – 117



Cafeteria and Breakout Chairs

Page 118 – 119



Public Seating

Page 120 – 124



Auditorium Seating

Page 125 – 129



Lounge Seating

Page 130 – 133



Active Seating Solution

Page 134 – 137



Cue

Page 138 – 142

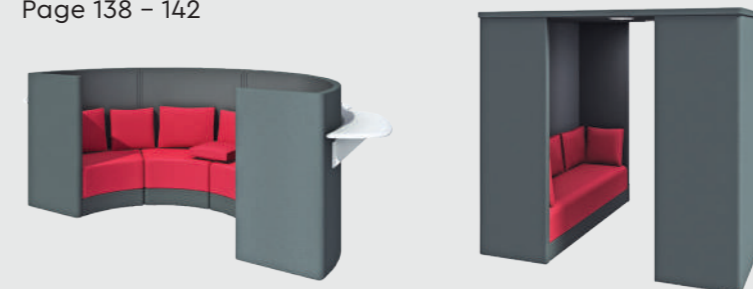

Index

Modular Workstations

Introduction

Page 145 – 147



Mobile Systems

Page 148 – 149



Panel-based Systems

Page 150 – 153



Desk-based Systems

Page 154 – 158



Storage

Aisle and Back Storage

Page 160 – 173



Modular Storage

Page 169



Display Storage

Page 174 – 177



Index

Storage

Modular Display

Page 176



Personal Storage

Page 178 – 182



Conventional Storage

Page 183 – 185

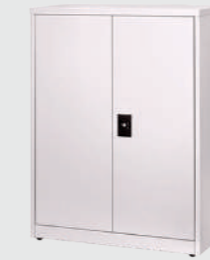

High Density Storage

Page 186 – 193



Social Office

Immerse Work Pod

Page 195



Assert Range

Page 196



Index

Social Office

Topo Range
Page 197



Tetris Range
Page 198



ORBB Range
Page 199



Graph Range
Page 200



Omega Range
Page 201



Personal Workstations
Page 202 – 203



Lamps
Page 204



Neo Bookshelf
Page 205

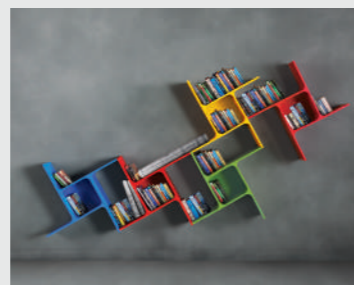

Index

Lounge

Sofas
Page 207

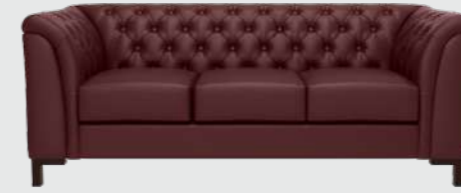

Centre Tables
Page 213



Executive Dining
Page 216



Colour, Finishes and Textures

Colour, Finishes and Textures
Page 219 – 229

Other Segments

Healthcare & Laboratory Furniture
Page 230 – 231





Partnering India In Building A Better Tomorrow.

We are India's largest home & institutional furniture manufacturer since 1936. With a focus on Make in India products, manufactured in state-of-the-art facilities meeting global design, quality and test standards.

Supporting modern nation-building with products, services and initiatives geared towards a greener, healthier, progressive and prosperous future.



125 Years Of Legacy. 1000+ Projects Delivered Annually.

With a rich legacy that spans over 125 years, Godrej is a pioneer across industries in India.

Led by India's largest in-house furniture design team, our aim is to transform spaces with thoughtfully-designed furniture. And our goal is to create brighter homes and offices with products that have the highest design quotient in aesthetics, functionality, and technology.

Godrej Interio at a glance

- India's largest home & institutional furniture manufacturer, since 1936; supporting nation building.
- 95% ex-works TOC performance through project tools and dedicated team to ensure on-time project delivery
- Unique customization capabilities
- Winner of 34 India Design Mark Awards till date.

Widest product portfolio across product lines

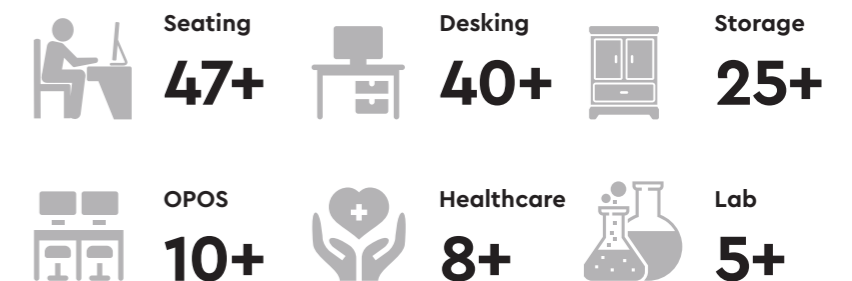

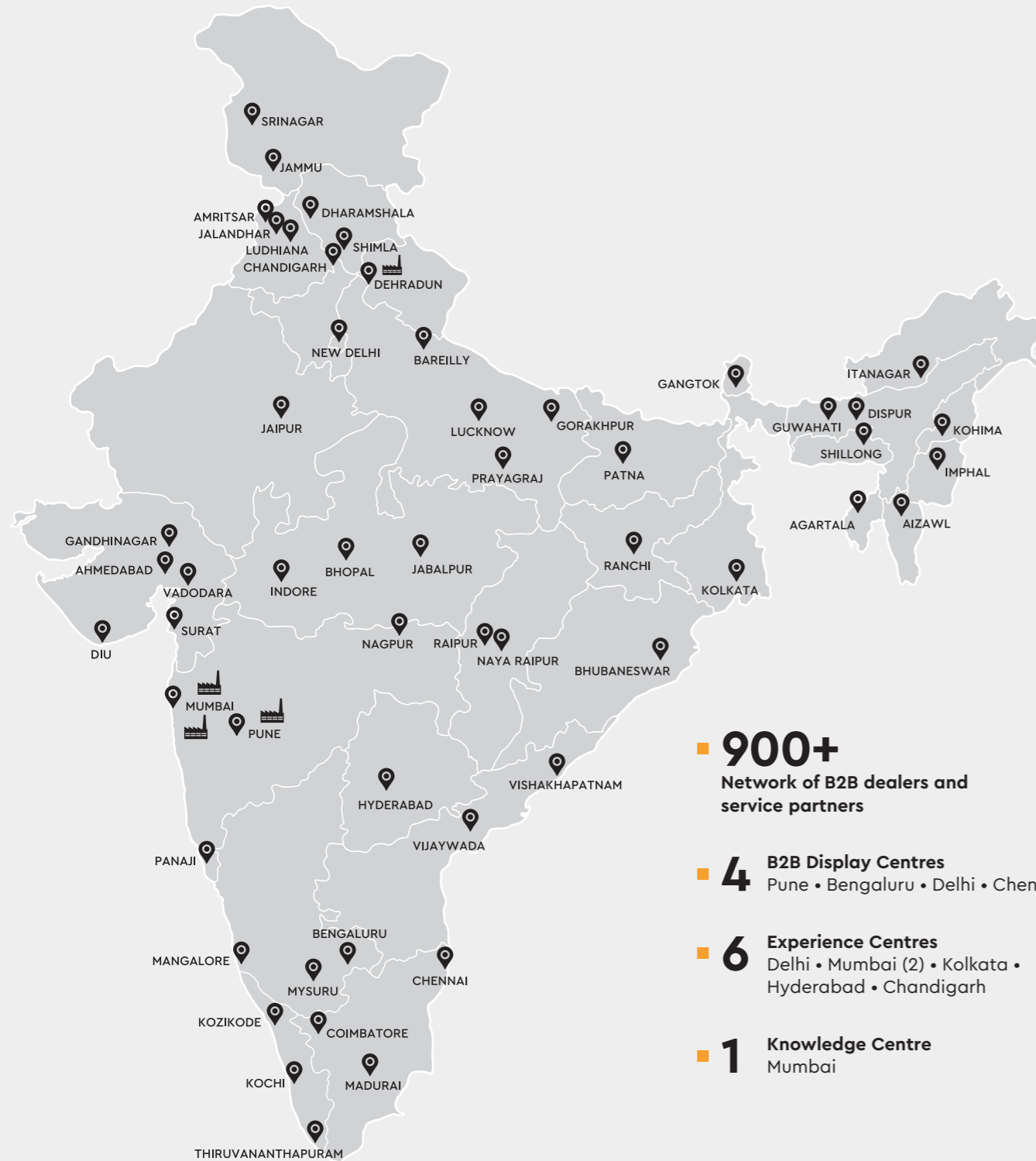

- **900+**
Network of B2B dealers and service partners
- **4** B2B Display Centres
Pune • Bengaluru • Delhi • Chennai
- **6** Experience Centres
Delhi • Mumbai (2) • Kolkata • Hyderabad • Chandigarh
- **1** Knowledge Centre
Mumbai

Our All India Presence

Get complete access to our wide range of workplace solutions across our 900+ dealers and partners in India. Manufactured at our facilities in Vikhroli, Shirwal, Khalapur, Haridwar, and Bhagwanpur, all our workplace products pass through multiple stringent quality checks before they reach you.

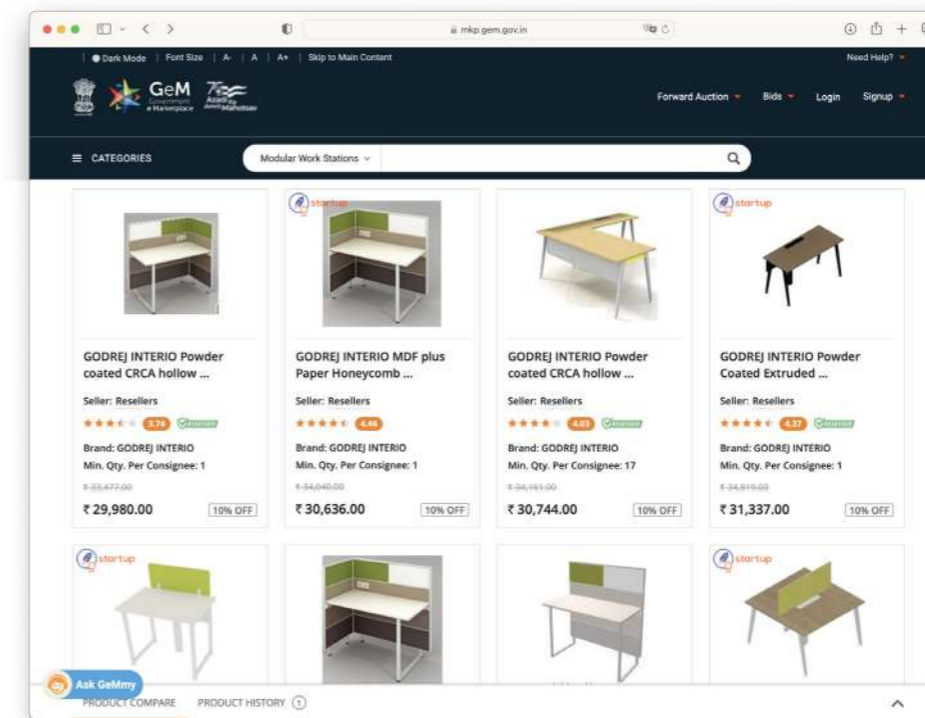

Rating of 4+ on GeM. Compliant & Widely Available.

Godrej Interio is the largest umbrella brand listed on the GeM portal: in 80+ categories under furniture and 190+ categories under office space. Interio has an overall rating of 4+ based on various parameters such as Delivery, Quality, Reliability and Feedback by buyers.

- Among **Top 15** Sellers Registered On GeM
- **60,000+** Product Listings
- **365+** Re-seller Network
- **100+** GeM Categories
- Products Listed In This Dossier Are Available On GeM Portal
- Additional Products Can Be Made Available As Per Requirement

Enforcing Green At Every Step

At Godrej Interio, our sustainability goals are ambitious. We do not just talk, we walk the talk.

We take our work seriously because we know our products and services touch people, transform lives and change the world.

When we add the element of sustainability and green living into what we do, it adds the positivity of hope to the promise of a better future, not only for people but for the planet as a whole.

Godrej interio
talk green.
walk green.



Materials

- Design For Environment
- Green Materials
- LCA



Transportation

- Green Modes Of Transportation



Manufacturing

- Energy Efficiency
- Zero Waste Water Discharge
- Renewal Energy
- Zero Waste Landfill



In Use

- Low Emitting Products
- Green Certification
- AMC



Packaging

- Flat Packaging
- Right Packaging



End Of Life

- Recycling Program
- Safe Disposal

India's First Net Zero Energy Building.

- CII certified state of the art manufacturing facilities across 6 locations
- Designed for the environment: Cradle to grave journey monitored



Largest Portfolio of Certified Products



Towards Healthier Workspaces

Godrej interio
wellness@work

- Team of certified doctors / ergonomists to assist employee health and productivity challenges at workplace

- Ergonomics Program helps organizations improve employee comfort, lowers injuries arising out of sedentary lifestyle at work

- Initiatives help reduce healthcare cost

- Team is backed by research and advisory experience spanning across corporate, government and healthcare organizations.



Cue Work Lounge

Features

- The CUE Work Lounge comprises standalone horizontal pouffes, curved pouffes, sofa sets, phone booths, and discussion carriages.
- You can combine these elements in any number of combinations and layouts, creating workspaces that are perfect for your teams and their activities.

Colour & Material

SOFA FABRIC SEATING

SEAT



Cardinal



Denim

BREAKOUT FABRIC SEATING

PANELS & BASE



Shadow



Cement Grey

Measurements

Meeting Booth

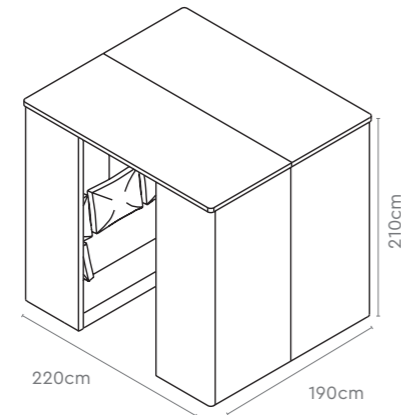

Phone Booth

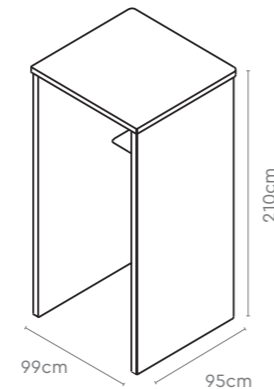

Tea Table

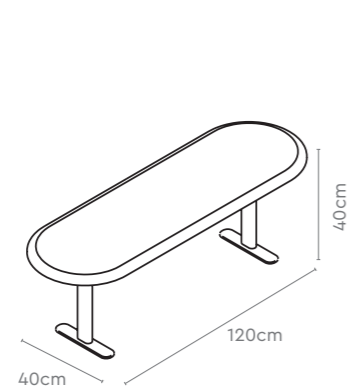

Media Screen

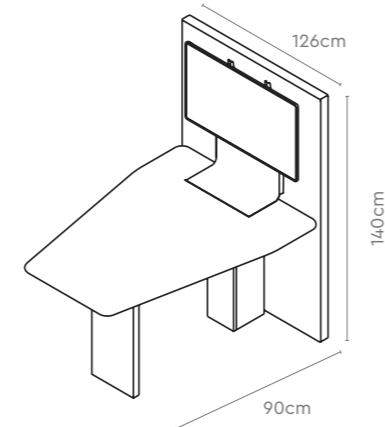

Design Registered

All sizes in cm	Width	Depth	Height
Meeting Booth	220.0	190.0	210.0
Phone Booth	99.0	95.0	210.0
Tea Table	120.0	40.0	40.0
Media Screen	90.0	126.0	140.0

Modular Workstations

Page 145

Introduction

Page 148

Mobile Systems

Page 150

Panel-based Systems

Page 154

Desk-based Systems

Modular Workstations

Workstations That Work As Hard As You Do.



In today's age of rapidly transforming businesses, workspaces are also becoming increasingly dynamic.

A workspace is no longer just a place where people sit and work. It's an extension of our ideas, our personality, and the way we get our work done.

Godrej Interio's Modular Workstations are designed keeping in mind the needs of new-age workspaces, and provide next-gen furniture solutions that inspire optimum performance.

Let's get working!

Configuring Workstations

Mobile Systems

Mobile Systems are workstations whose layouts are not set in stone. They are designed for workspaces that prefer immediate flexibility and reconfigurability of their layouts, which can be done by the user as per their space utility requirements.

- Habitat

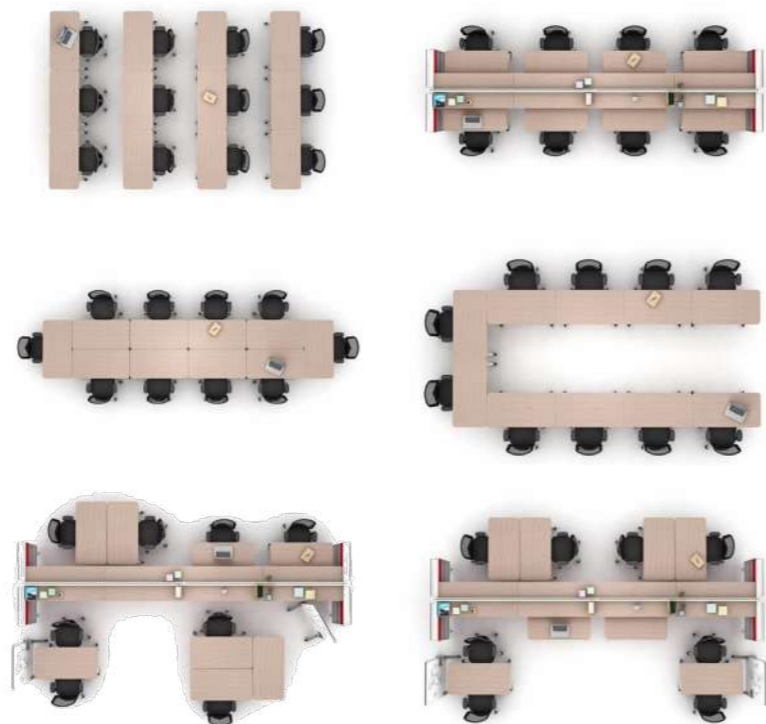

Mobile Systems: Habitat

Panel-based Systems

Panel Based Systems add depth to your office space. Their contemporary designs are not only pleasing to the eye, but also highly flexible in nature. These allow for office layouts to be planned around existing oddities within the workspace.

- Wish
- Frontier
- Xpress
- Wall

Desk-based Systems

Desk Based Systems are workspace configurations with sliding worktops and monitor holders. These modules can be used for collaborative work when required, as well as individual focused work tables when not in a meeting mode.

- Dfine
- Reason
- Upbeat
- Upbeat+



Panel Based Systems: Wall



Desk-Based Systems: Dfine

Mobile Systems:
Habitat



Design Registered



Features

- Habitat is an all-in-one workspace solution for corporations that place an equal emphasis on aesthetics, functionality, and sustainability.
- It's designed for workspaces that prefer immediate flexibility and reconfigurability of their layouts, which can be done by the user as per their space utility requirements.
- Comes with panels with glass screens above worktop level for an open and transparent look.
- You can also opt for different types of glass finishes, like laminated coloured glass, ceramic printed glass etc.
- The tables can be reconfigured, folded, and stacked horizontally as per your utility.
- Accessories like name plate, single and double sided shelf, as well as the magnetic rail on the glass screen are provided to accentuate the aesthetics and functionality of the workstation.
- A CPU holder is attached to the panel, clearing up floor space.
- Not meant for price sensitive customers like the IT/ITES segments.

Accessories



MIMO (Mobile Interactive Media Unit)

Mobile Marker Board Screen



Portable Power Post

Ethos Task Light (Floor-Mounted)

Ethos Task Light (Desk-Mounted)



Fold Table

CPU Holder



Name Plate

Open Shelf (Single)

Open Shelf (Double)

Panel-based Systems:

Wish



Design Registered



Features

- Godrej Interio's Wish fulfils your wish for a workstation with infinite flexibility of configuration.
- It's born from the current international trend of 'going horizontal'. I.e. Creating an impression of added depth to your office space.
- This contemporary concept is not only pleasing to the eye, but also highly flexible in nature, allowing office layouts to be planned around existing oddities within the workspace.
- It's designed to be able to fit into any office layout, by creatively utilising even ungainly outcrops such as pesky columns into the design of the workspace layout.

- This capability of being highly accommodative is possible because of the ingeniously-crafted horizontal panels that comprise its structure.
- The sleek gapless panels with their proportional visual lines provide the workstations with a modern look and feel.
- Creative layout plans can result in a variety of looks for offices, such as a single colour monolithic look, a classic wooden look, a multicolor tiered look, an artistic acrylic finish, or even a post-modern transparent or translucent glassy look.

Details

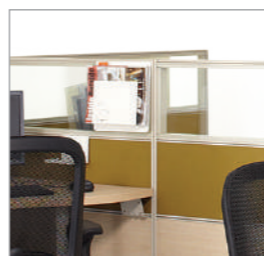

Panel-based Systems:

Frontier



Features

- The Frontier is the next step towards an all-modular workspace solution.
- Suitable for banking corporations with multiple branches across locations, as the Frontier is factory-finished, therefore allowing for all individual branches to have a uniform look and feel.
- Thoughtfully designed to ensure complete safety to the user as well as the visitor.
- Comes in a ready-to-install format from the manufacturing plant itself, thereby reducing the site completion timeline.

- Modules available for different functions like
 - Cashier (7' standing interaction counter)
 - Executives (sitting interaction counter)
 - Manager Modules
- Enjoy a clutter-free worktop, as The Frontier comes with provisions for concealed wiring in the panel itself.

Details



Panel-based Systems: Xpress Office



Features

- The new Xpress Office is a quick-buy option in modular office furniture, and a one-stop solution for all office interiors issues.
- Comes in 4 colour schemes to choose from, and with over 100 variants when different configurations and sizes are paired together.
- As all the upholstery and the switch-mounting provisions come assembled from the manufacturing plant itself, setting up an Xpress Office is quick and easy, needing only the installation of the modules at your location.
- With better delivery schedules and faster installation time, it is available in the EDP range of furnitures.



Panel-based Systems: Wall Full Height Partitions



Features

- Wall is a partition solution that blends contemporary workspace aesthetics with the comfort of speedy execution.
- It's a gapless, modular, full-height partition system, designed to provide an aesthetic appeal while also catering to the general functional needs of an office space.
- Comes in an expansive collection of tile finishes and functions, enabling you to create spaces that enhance productivity.
- Has provisions for writing surfaces, display shelves, and a monitor mounting switch. It also comes equipped with an efficient wire management system within the panels.

Details



Desk-based Systems:

Reason



Design Registered



Features

- Godrej Interio's Reason Workstation is a global design that's truly Indian at heart.
- It combines our unique understanding of Indian consumers with globally-cherished designs, offering benching solutions, return units, sit/stand units, overhead storage units etc.
- Reason is the perfect solution for collaborative workspaces, with the sit/stand unit enabling seamless impromptu meetings.
- Comes with a concealed wire management system that provides a neat and clutter-free worktop.

Details



Configurations



Desk-based Systems:

Dfine



Design Registered



Features

- Dfine is a workspace configuration with sliding worktops and monitor holders.
- Its modules can be used for collaborative work when required, as well as individual focused work tables when not in a meeting mode.
- Comes with the provision for meeting pods within the workstation clusters, combined with the possibility of having marker surfaces as well as a screen mounting facilities.
- The Credenza provides ample storage space for files and stationery, while also ensuring that there's room for the CPU/ laptop bags.
- Can be configured to create a horizontal structure, allowing team leaders to seamlessly gel with their employees, or with cabins to provide private offices for vertical structures.

Details

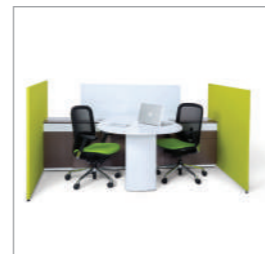

Desk-based Systems:

Upbeat



Patent Filed & Design Registered



Features

- Upbeat is a complete office furniture setup solution, designed to cater to the various settings in an office space.
- Comes with five different leg designs, and a range of screen finishes and looks which can be mixed-and-matched to create unique office spaces.
- Different options for wire management and design accessories add to the flexibility of the workstation offering.
- It also provides an exhaustive range of sizes and configurations which allow users to create clusters on the basis of their needs.

- The configurations that could be created with Upbeat are
 - Regular Tables
 - High Tables
 - Mobile Tables
 - Meeting Tables
 - Conference Tables

Details

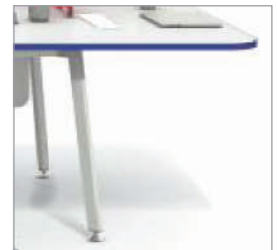

Desk-based Systems:

Upbeat+



Design Registered

Features

- Upbeat+ is a complete office furniture setup solution, designed to cater to the various settings in an office space.
- Comes with five different leg designs, and a range of screen finishes and looks which can be mixed-and-matched to create unique office spaces.
- Different options for wire management and design accessories add to the flexibility of the workstation offering.
- It also provides an exhaustive range of sizes and configurations which allow users to create clusters on the basis of their needs.

Details



Storage

Page 160**Aisle and Back Storage****Page 178****Personal Storage****Page 186****High Density Storage****Page 174****Display Storage****Page 183****Conventional Storage**

SPECTRUM

THE COLOUR EXPERIENCE

Colours, Materials, Finishes and Textures

Godrej Interio's Colour System — Spectrum — presents infinite possibilities for creating fresh and inspiring themes for workplaces. In the following pages, we demonstrate some of these possibilities using a curation of workplace themes, and a glimpse of the 100+ colours, materials, finishes and textures we offer.

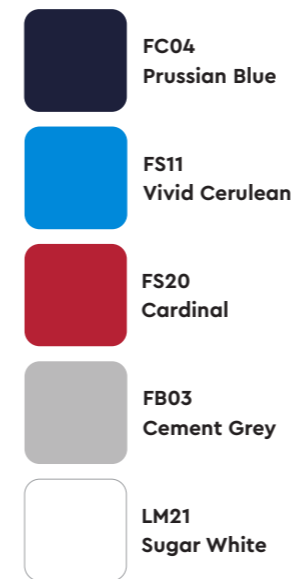

Inspired by Culture

A city rich in history, Jodhpur's architecture, colours and people signify a beautiful blend of traditions and warmth. Even as the city is adapting to urbanization, it communicates to stay rooted while exploring the new.

Inspired by Flavour

Spices define the nature of food, their intensity and combinations can enhance the punch in the flavour. A combination of such colours and materials triggers the required spark for an interesting conversation.





- FO69 Luminous
- PW34 Texas Yellow
- FB03 Cement Grey
- FO24 Blue Iceberg
- LM21 Sugar White

Inspired by Spry

Playing sports is not only a wonderful way to stay fit but it is also one of the best stress busters. Aspects of a game such as energy, team spirit and problem solving are synonymous to today's workforce.



- PW16 Sunset Sky
- PW11 Vivid Cerulean
- PW27 Sugar White
- MB114 Verade Oak Soft Natural

Inspired by Summer

A little bit of summer vacation is what might be the best time of the year; a sense of serene space may be with friends, sun, sand and sea is a longing state of mind.

Inspired by Refresh

Urban spaces have made us detached from nature. A refreshing, exhilarating experience of space with greens is a welcome break.

- FO14 Vitamin Bright
- FO33 Tree Mist
- PW27 Tex Bond White
- LM44 Warm Grey
- MB116 Amati PC







Inspired by Zest

Food is a dominant part of one's culture that helps strengthen the community at a workspace, and chilies are the most common ingredients that can bind multi-cultural cuisines together.



- FL06 Garnet
- PW27 Tex Bond White
- PW14 Gargoyle
- FK01 Black Ink
- LM104 Kitami Elm



-  FL04
Prussian Blue
-  LT52
Dark Tan
-  FL01
Black Ink
-  MB112
Tobacco Ash

Inspired by Regal

A meet that could shape the future needs the right setting and tone. An earthy and contemporary palette brings a feeling of power and authority.







Inspired by Active

Health is the highest priority for a new age worker. Healthy living is a growing focus area that urges us to practice an active lifestyle even at work. It makes us feel positive, energetic and motivated.

-  FS05
Leaf Green
-  FC02
Dark Tangerine
-  FS20
Cardinal
-  PW11
Vivid Cerulean
-  LM21
Sugar White

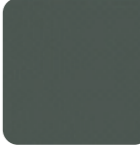

Foam Laminated Fabric Seating (FL)

-  FL01
Black Ink
-  FL04
Prussian Blue
-  FL06
Garnet
-  FL07
Royal Blue
-  FL08
Saddle Brown
-  FL10
Earth Stone
-  FL14
Vitamin Bright
-  FL56
Amethyst Regale

Breakout Fabric Seating (FB)

-  FB03
Cement Grey
-  FB04
Ink
-  FB18
Milan Red
-  FB51
Shadow

Sofa Fabric Seating (FS)

-  FS02
Dark Tangerine
-  FS04
Denim
-  FS05
Leaf Green
-  FS11
Vivid Cerulean
-  FS20
Cardinal
-  FS72
Mink
-  Peacock
-  Flame
-  Citron
-  Cement Grey

Crepe Fabric Seating (FC)

Voila



Knitted Fabric Seating (FK)

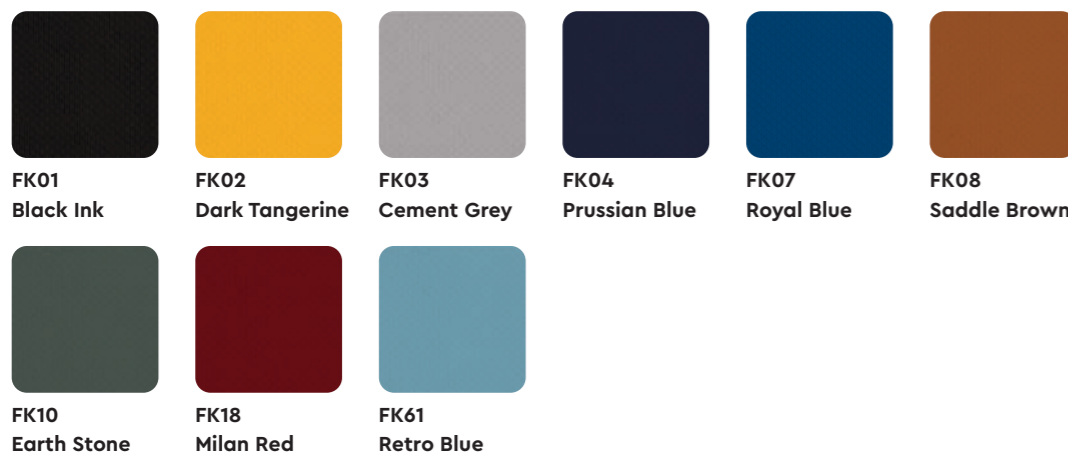

Leatherette Sofa (LS)



Leather (LT)



Leatherette Chair (LC)



Net / Micro Mesh / Spacer Fabric Seating (NM & SF)

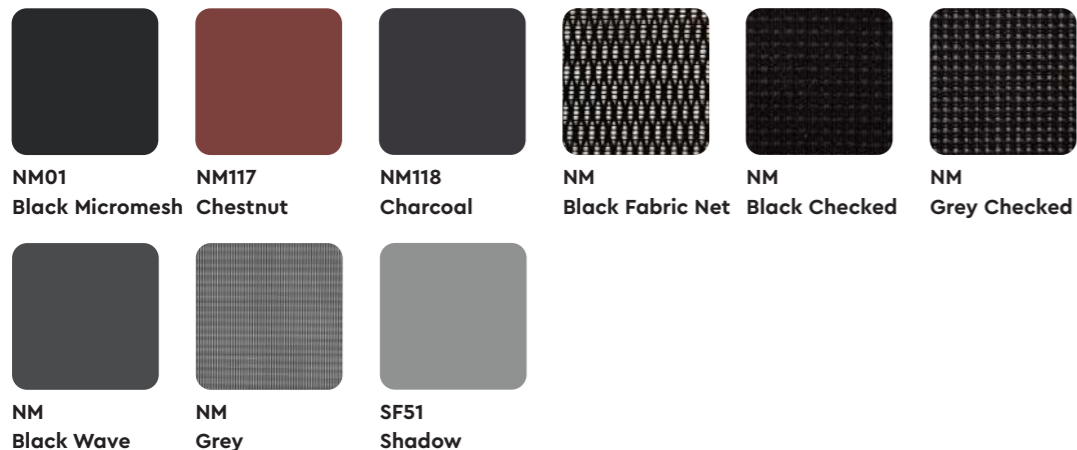

Plush Fabric (FP)



Unwind Range



Laminate (LM)

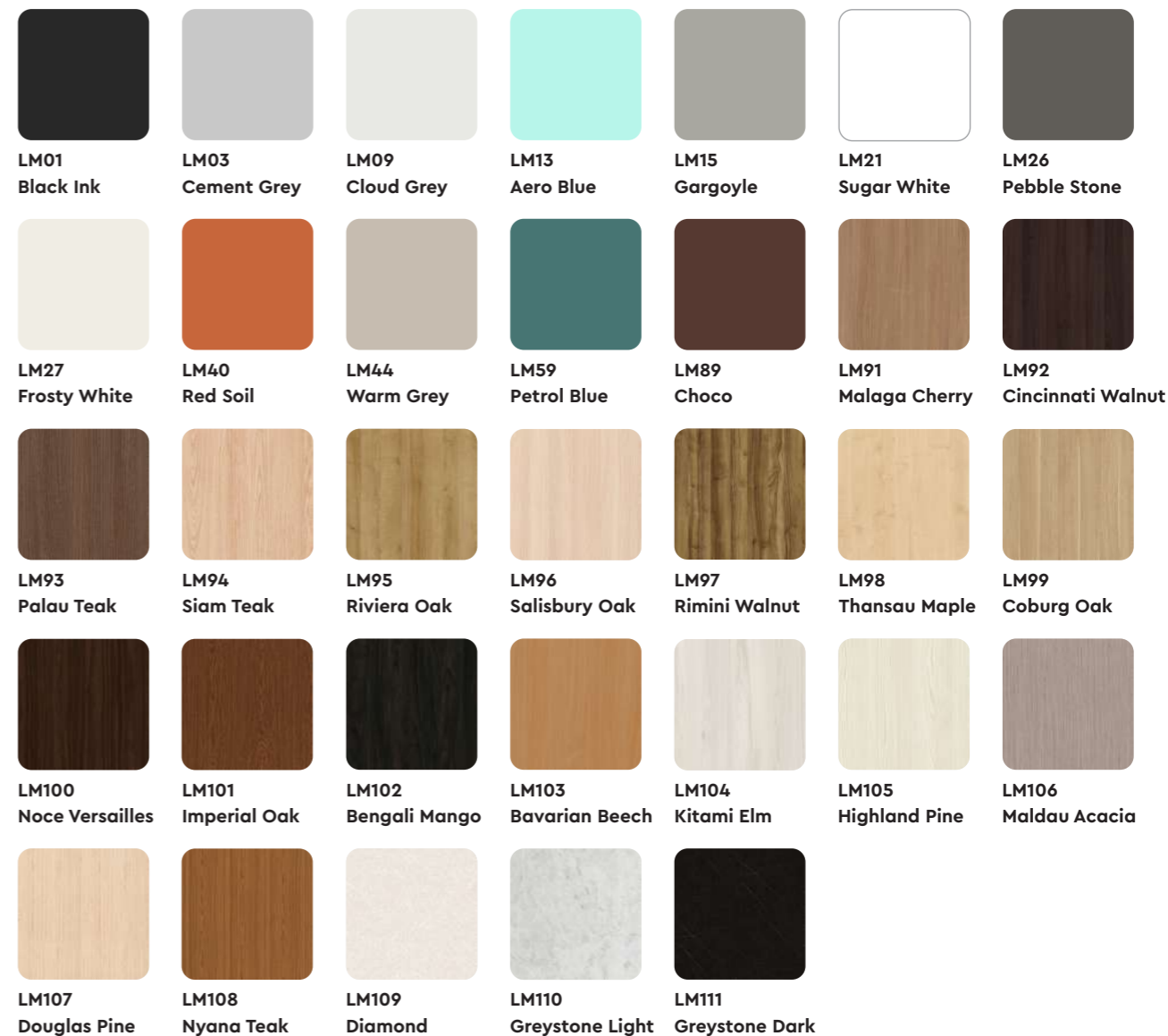

Membrane Range (MB)

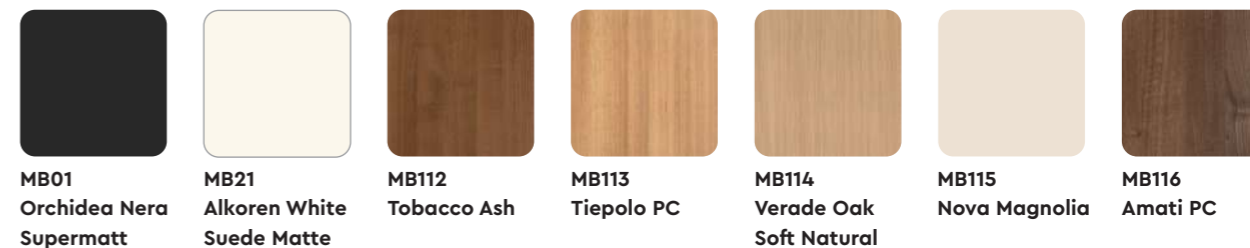

Fabric Modular (FO)

						
FO02 Dark Tangerine	FO03 Cement Grey	FO04 Prussian Blue	FO05 Leaf Green	FO06 Garnet	FO07 Royal Blue	FO08 Saddle Brown
						
FO10 Earth Stone	FO11 Vivid Cerulean	FO12 Azure	FO13 Aero Bue	FO14 Vitamin Bright	FO15 Gargoyle	FO16 Sunset Sky
						
FO19 Indian Red Chili	FO20 Cardinal	FO22 Orchid Purple	FO24 Blue Iceberg	FO25 Country Green	FO28 Boysenberry	FO29 Amethyst
						
FO30 Powder Blue	FO31 Blue Grass	FO33 Tree Mist	FO35 Victorian Gold	FO36 Cream	FO38 Oranger Spark	FO39 Burnt Orange
						
FO41 Young Wine	FO42 Copper Moon	FO44 Warm Grey	FO45 Stone Path	FO46 Roasted Bean	FO47 Champagne	FO54 Fresh Leaf
						
FO55 Plum Pastel	FO57 Baby Blue	FO58 Caspian Sea	FO60 Blue Ivy	FO62 Citrus	FO63 Green Sea	FO65 Conifer
						
FO67 Jungle Cane	FO69 Luminous	FO70 Fuchsia	FO70 Jaipur Pink	FO73 White Sand	FO75 Acron	FO76 Indian Coffee
						
FO85 Granada	FO86 Latte	FO87 Sliver Line	FO88 Caramel			

Powder Coat (PW)

						
PW01 Black Ink	PW02 Dark Tangerine	PW03 Cement Grey	PW04 Prussian Blue	PW05 Leaf Green	PW06 Garnet	PW09 Cloud Grey
						
PW11 Vivid Cerulean	PW13 Aero Blue	PW14 Gargoyle	PW16 Sunset Sky	PW18 Indian Red Chilli	PW20 Cardinal	PW21 Sugar White
						
PW24 Blue Iceberg	PW26 Pebble Stone	PW27 Tex Bond White	PW33 Tree Mist	PW34 Texas Yellow	PW40 Red Soil	PW41 Young Wine
						
PW44 Warm Grey	PW48 Slate Grey	PW54 Fresh Leaf	PW66 Lime	PW68 Banana Yellow	PW74 Horizon	PW78 Medieval Town
						
PW81 Sepia Brown	PW82 Prince Grey	PW83 Platinum Silver	Matt Taupe White			

Godrej interio

HEALTHCARE

Visit our Healthcare Experience Centre to experience the latest healthcare products from our range, firsthand — from patient care, to medical screening to office & leisure furniture.

Products Available: ICU Beds, Examination Beds, Gynaec Examination Couch, Recovery Bed, Emergency Trolley, Nursing Station, Office Furniture and more.



Lab



Fusion



Nucleus



Aeolus

Godrej interio

Available in over 600 locations in India.

North: Delhi, Chandigarh, NCR, Lucknow
South: Chennai, Bengaluru, Hyderabad, Kochi
West: Mumbai, Ahmedabad, Bhopal, Pune
East: Kolkata, Bhubaneswar, Guwahati, Patna

Godrej & Boyce Mfg. Co. Ltd.

Godrej Interio,
Pirojshanagar, Vikhroli (W),
Mumbai 400 079

Toll Free Number: 1800-209-5511

Email: interiooffice@godrej.com

Fax: +91-22-6796 1503

Put some play into your work by visiting
godrejinterio.com/business

Follow us on /godrejinterio



Godrej interio

talk green.
walk green.

An initiative by Godrej Interio,
the first Indian furniture
company with GREENGUARD
certified products.



India's
Most Desired Brand
TRA Research
Furniture Category
July 2021



India's
Most Trusted Brand
TRA Research
Furniture Category
February 2022



**Franchise India
Retail Brand
of the Year**
Speciality/Furniture
Retail Category
December 2022



Marksmen Daily
Most Preferred Brand
2022

MODULAR FURNITURE . DESKING . SEATING . STORAGE . INTERIORS . LAB . HEALTHCARE . HOME



The GREENGUARD Certification Program gives assurance that products designed for use in indoor spaces meet strict chemical emission limits, which create healthier interiors. The certification qualifies for LEED credits and IGBC credits.

In keeping with the Godrej policy of continuous development and improvement, the design, dimension and specification may be updated without prior notice or obligations. Form, Colour and Finish of product in this document are representative of design intent and may vary from actual. Colour options depicted in this catalogue are as close to what modern printing processes allow. All dimensions are in 'cm' and are subject to commercial tolerance. Our products are meant for indoor use only.

B2BGOVTDOSI2023